

# GUHRING

## PCD/CBN TECHNOLOGY

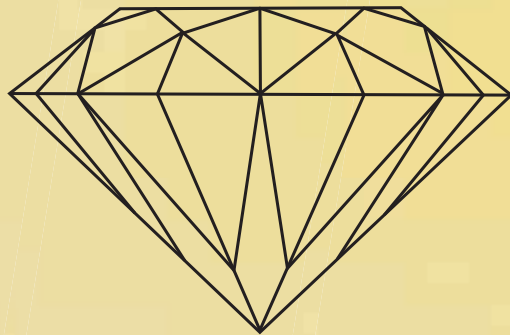



Intelligent solutions  
for complex  
machining tasks



# INTERCHANGEABLE HEAD MILLING CUTTER

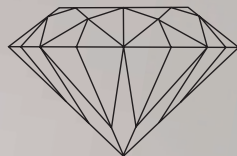

Flexible, wear-resistant, highly accurate:

The interchangeable head milling cutter, consisting of cutting head and clamping chuck, can be re-fitted with a new head in seconds. Axially and radially adjustable as well as extreme clamping force, it promises accurate concentricity. Exceptional performance with maximum cutting rates and reduced machining times.



---

This publication may not, in part or whole, be reproduced.

The publishers cannot be held responsible for any errors, omissions or changes of any kind. All products marked with "DIN", deviating from the dimensions listed in the catalogue, can be delivered, as long as they are in conformity with the DIN standard form.

Printed in Germany

Guehring KG  
P.O. Box 10 02 47  
D-72423 Albstadt

Herderstraße 50-54  
D-72458 Albstadt

Tel.: +49 74 31 17-0  
Fax: +49 74 31 17-21 279  
Internet: [www.guehring.de](http://www.guehring.de)  
E-Mail: [info@guehring.de](mailto:info@guehring.de)

Guhring's injector bore drill promises perfect chip evacuation for High Speed Cylinder Head machining. Several flutes optimally evacuate chips of various size.



# INJECTOR BORE DRILL

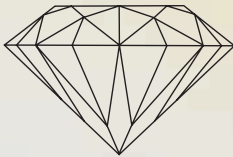

# High-performance tool material combined with innovative technologies

## Longstanding expertise

The development and manufacture of PCD/CBN tools has counted to Guhring's core activities for more than 30 years. At Guhring production facilities all over the world innovative complex tools with PCD/CBN cutting edges are produced for highly specialised machining operations.

## More performance, less tooling

PCD/CBN complex tools from Guhring guarantee short cycle times and high feed rates with consistent quality, exact repeatability and accuracy. High wear-resistance results in long tool life and permits efficient cutting data. High process reliability and accurate machining of difficult-to-machine materials is ensured. PCD/CBN complex tools combine several tools into one – therefore considerably reducing the manufacturing process.

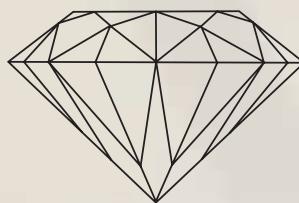

**PCD/CBN** TECHNOLOGY



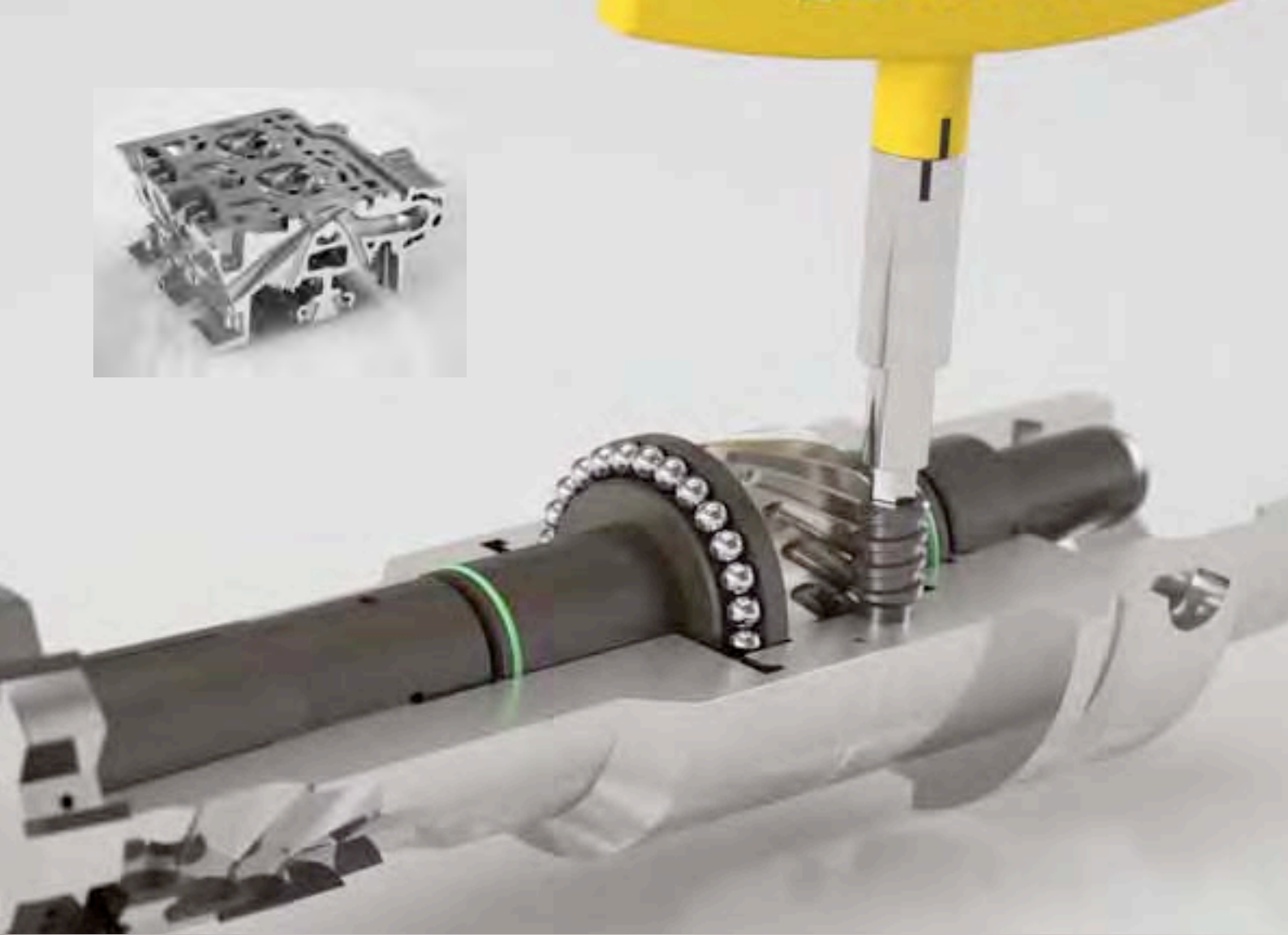

# WATER JACKET BORE



# Everything from one supplier – comprehensive and global

A world-wide net of production centres develops and produces Guhring PCD/CBN high-tech tools for all important global markets. Uniform technical standards and machinery ensure highest quality, no matter from which location the tools originate. With innovative technologies Guhring meets individual customer requirements for all PCD/CBN complex tool matters – precisely, economically, flexibly, timely and globally.

With many years of know-how, Guhring provides support to its customers from process design to tool application for series production. Experts are internationally active looking after customers on-site. Production, service and contact persons are available world-wide from one supplier.

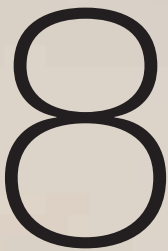

SALES COMPANIES

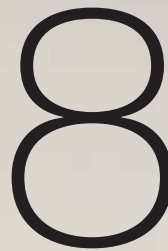

PRODUCTION PLANTS

**Guhring Inc.**  
1445 Commerce Ave.  
Brookfield, WI 53045  
Tel. +1 26 27 84 67 30  
Fax +1 26 27 84 90 96  
sales@guhring.com  
www.guhring.com

1



**Guhring Ltd.**  
Castle Bromwich Business Park  
Tameside Drive  
Birmingham B35 7AG  
Tel. +44 12 17 49 55 44  
Fax +44 12 17 76 72 24  
info@guhring.co.uk  
www.guhring.co.uk

2



**Guhring KG**  
Sigmaringer Str. 160  
72458 Albstadt  
Tel. +49 74 31 17 0  
Fax +49 74 31 17 21 27 9  
info@guehring.de  
www.guehring.de

3



**Guhring s.r.o.**  
Na Perkách 608  
33021 Line-Sulkov  
Tel. +42 037 79 11 01 6  
Fax +42 037 79 11 01 8  
infomace@guehring.cz  
www.guehring.cz

4



[www.guehring.de](http://www.guehring.de)







**Guhring Sp. z o.o.**  
 Aleja Zagłębia Dąbrowskiego 21  
 41-300 Dąbrowa Górnicza  
 Tel. +48 32 428 70 19  
 Fax +48 32 428 70 44  
 handel@guehring.pl  
 www.guehring.pl

5



**Guhring India Pvt. Ltd.**  
 Plot No. 129, Bommasandra Ind.  
 Area  
 Anekal Taluk 4th Phase  
 560 099 Bangalore  
 Tel. +91 80 40 32 2500-2509  
 Fax +91 80 40 32 25 10  
 info@guhring.in  
 www.guhring.in

6



**Guhring (Changzou)  
 Cutting Tools Co. Ltd**  
 No. 19, E Mei Shan Road  
 Xin Bei District  
 213022 Changzhou  
 Tel. +86 51 98 51 09 71 3  
 Fax +86 51 98 51 04 83 2  
 info@guhringchina.com  
 www.guhringchina.com

7



**Guhring Korea Co. Ltd.**  
 Gwangmyung-Si  
 8th Floor, ACE- GWANGMYUNG Tower  
 Soha-Dong  
 423-050 Kyunggi-Do  
 Tel. +82 2-2689-8542  
 Fax +82 2-2689-9732  
 info@guhring.co.kr  
 www.guhring.co.kr

8



[www.guehring.de](http://www.guehring.de)



# AUTOMOTIVE

01



## MOTOR

Page 10

Cylinder head

Page 12

Cylinder head cover

Page 20

Crankcase

Page 24

02



## DRIVE

Page 30

Gear

Page 32

Valve housing

Page 34

Pump housing

Page 36

03

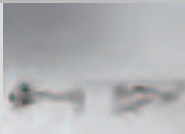

## AXLES AND STEERING

Page 38

Wheel carrier

Page 40

Axle uprights

Page 42

Steering column

Page 44

Joint machining

Page 46

04

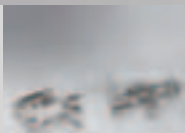

## BRAKES

Page 48

Brake caliper

Page 50

Brake cylinder

Page 52

Brake disc

Page 54

05



## SPECIAL SOLUTIONS

Page 56



# AEROSPACE LIGHTWEIGHT CONSTRUCTION

Page 66



## 06

## STANDARD TOOLS AND ISO INSERTS

Page 74

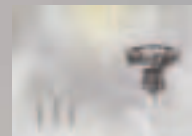

## 07

---

### TECHNICAL SECTION

PCD Basics  
Modules 6x6 and 4x4  
Setting and handling notes

Page 118  
Page 121  
Page 130

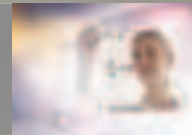

## 08



# AUTON

SPECIAL REQUIREMENTS,  
PRECISE SOLUTIONS



# MOTIVE

Modern automotive manufacturing relies on the application of high specification materials that are sometimes difficult to machine. Typical components such as engine blocks, cylinder heads or transmission housings put special demands such as wear-resistance and accuracy and – fields of application ideally suited to PCD complex tools from Guhring.

On the following pages we present some tooling solutions developed by us for the engine and other automotive components, transmissions and chassis parts.

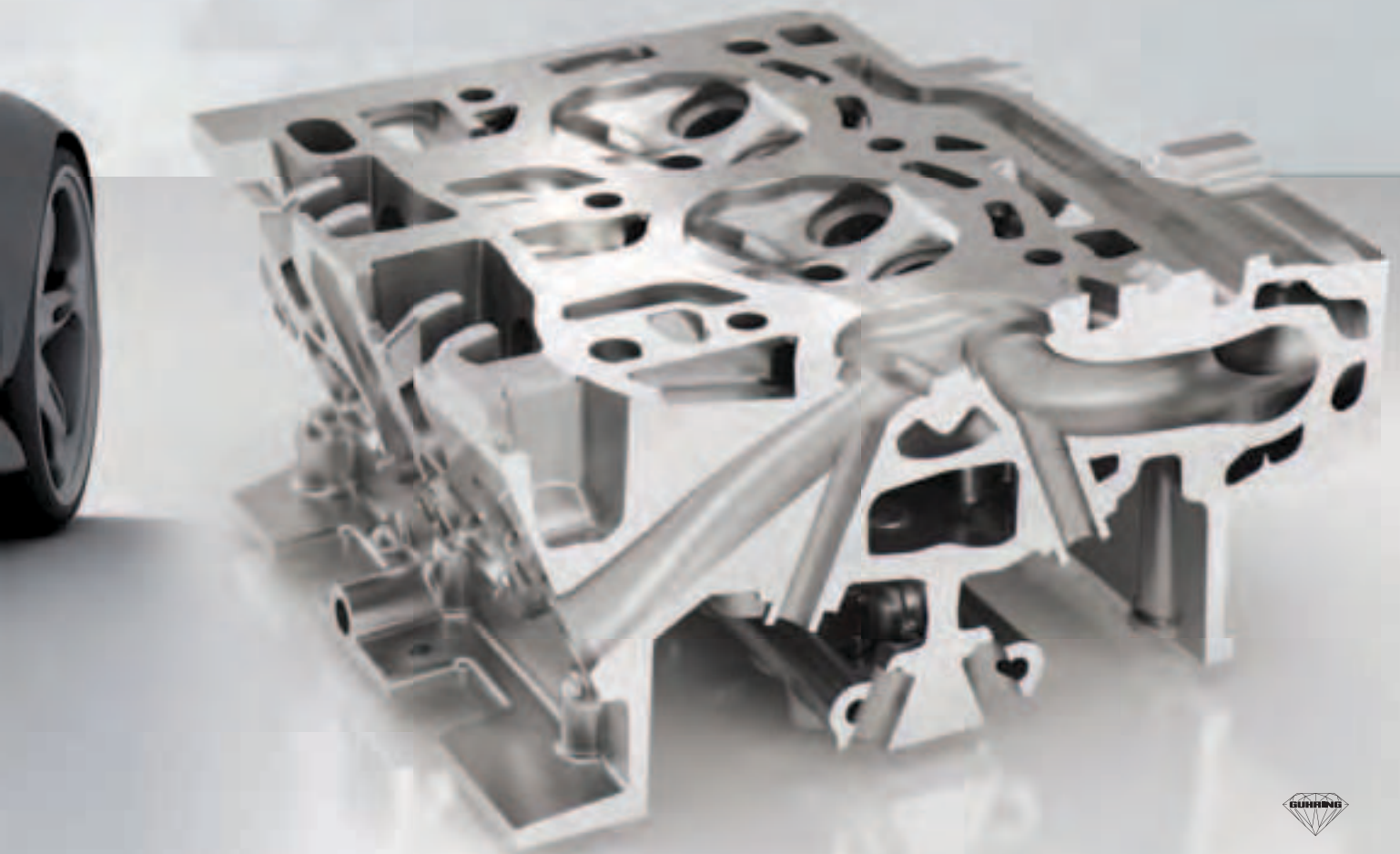

# MOTOR

## CYLINDER HEAD

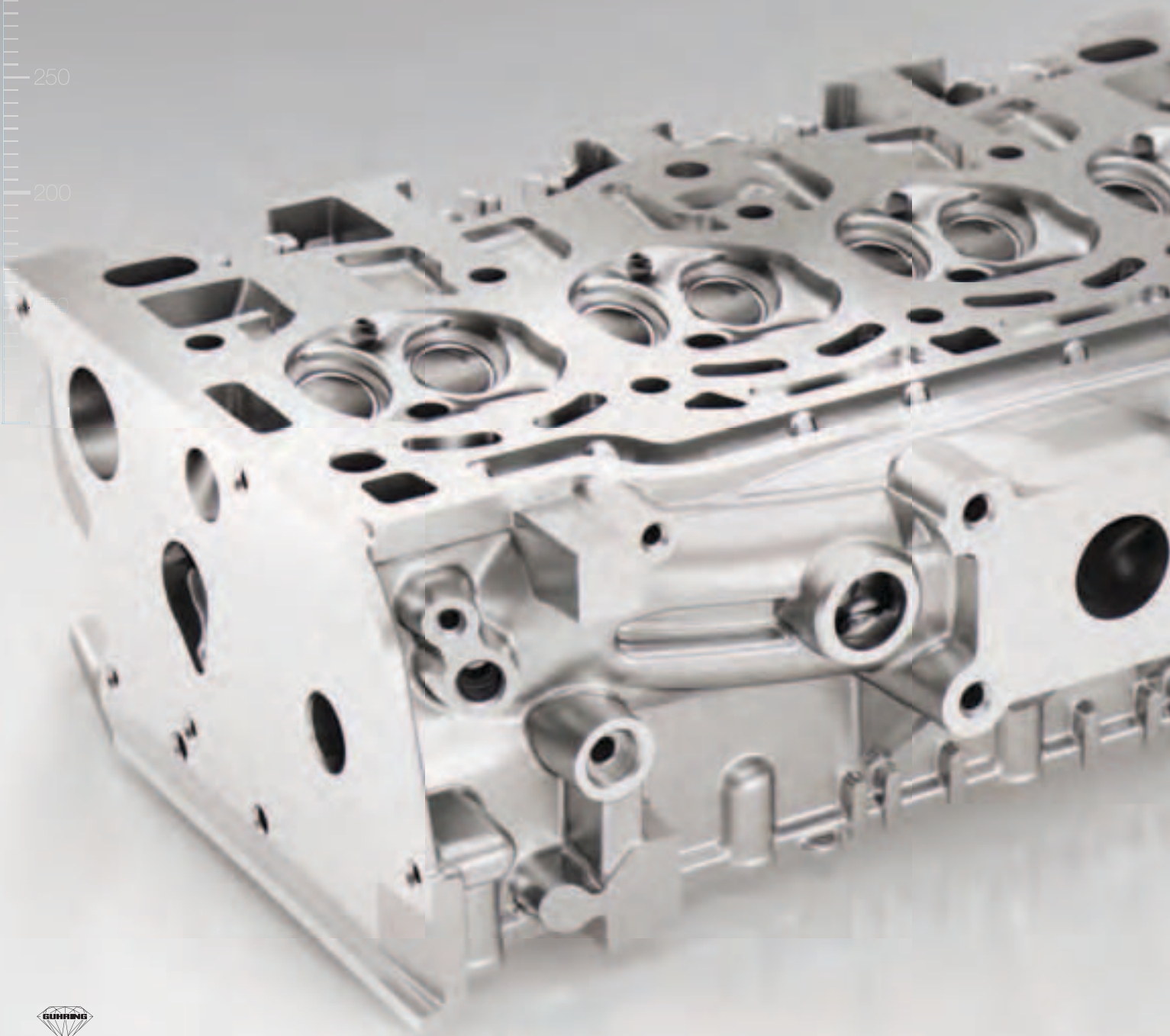

# HIGHEST PERFORMANCE THANKS TO HIGHLY ACCURATE MACHINING

Guhring designs and manufactures PCD tools for all machining tasks related to modern high performance engines. Machining components such as the cylinder head or crank case requires many closely positioned holes, the machining of which generates high temperatures. Due to such heat there is a risk of deformation of the precision holes. Guhring's PCD tools possess special cutting edge geometries. The risk of deformation is significantly reduced and accurate holes guaranteed.

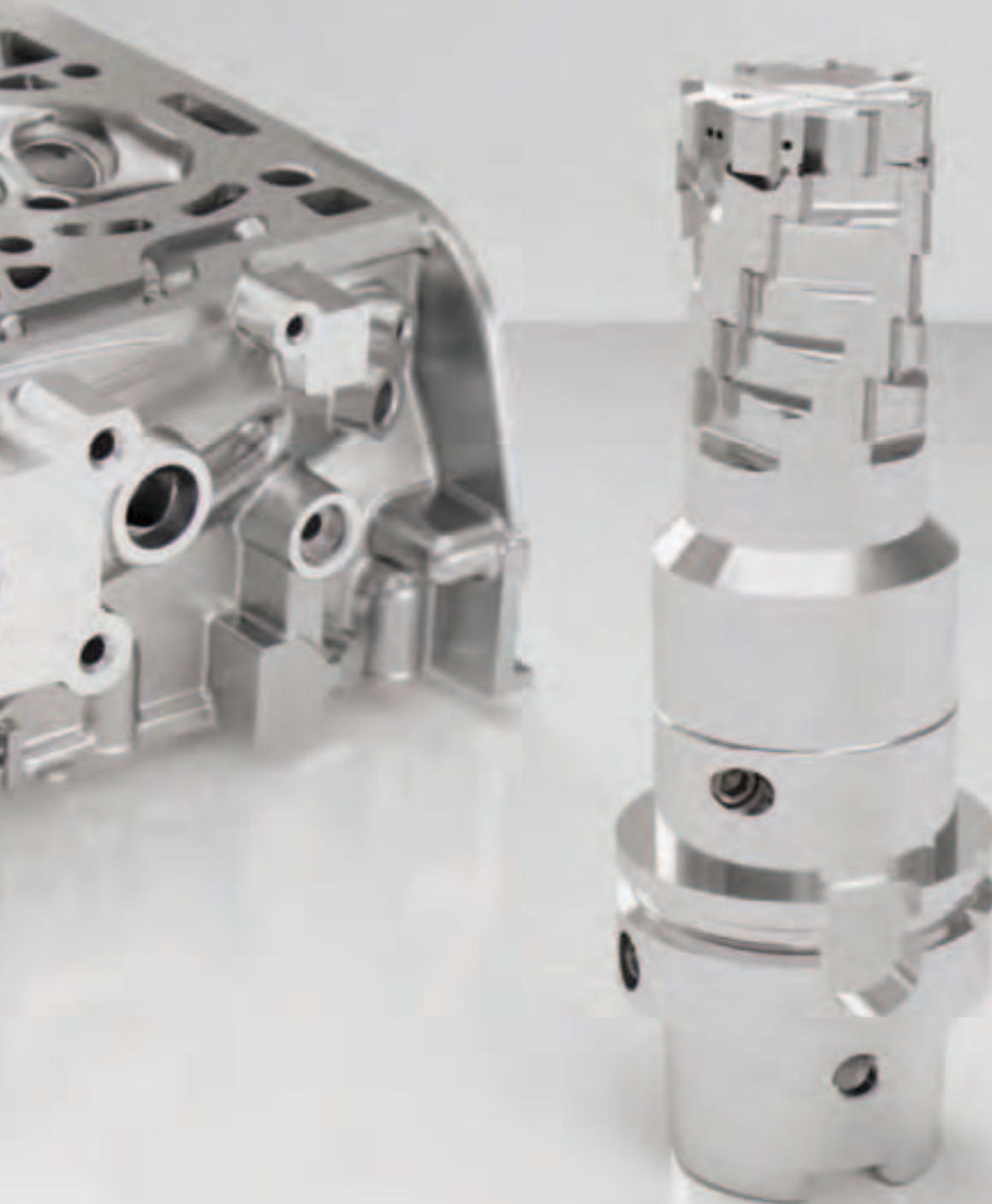

# MOTOR Cylinder head

# 01

## WATER JACKET BORE

This system for chip evacuation is ideally suited for holes when chips are not permitted to enter inside the workpiece. The special geometry of the water jacket drill ensures the chips are rolled and directed away from the workpiece by the back-pressure of the coolant. Contamination of the cylinder head is, therefore, greatly reduced.

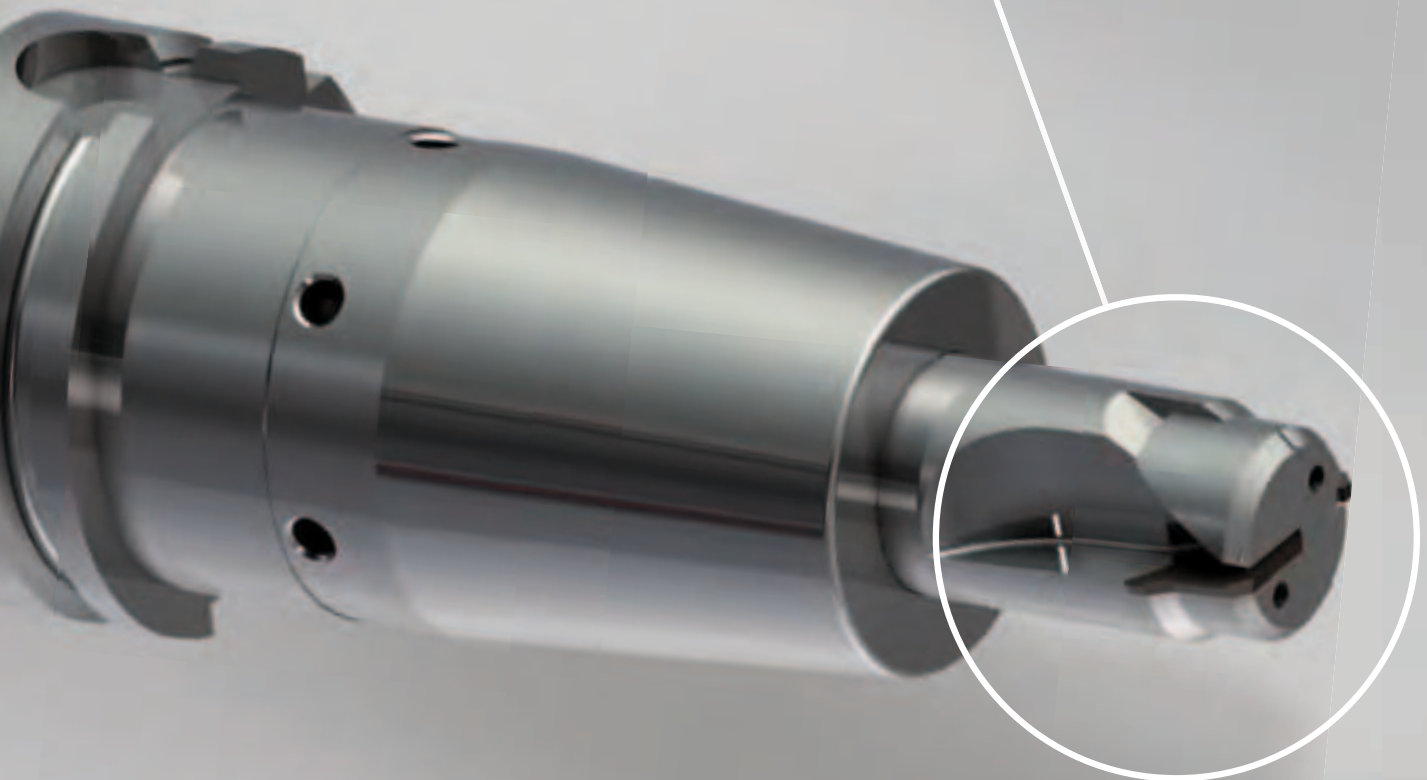
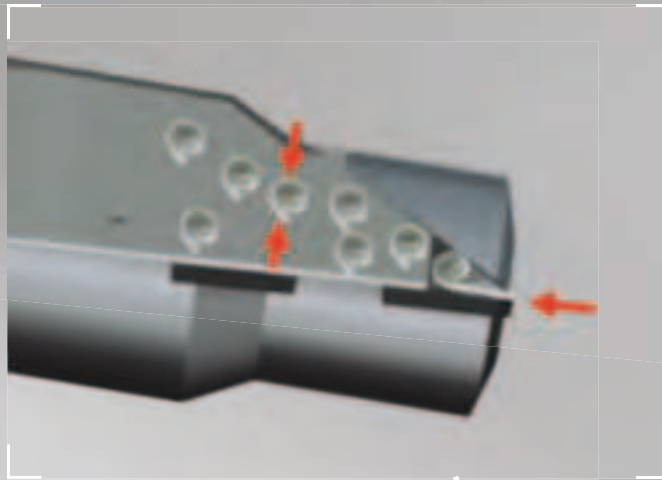



# PRE-MACHINING VALVE SEAT BORE

This solid carbide version offers highest rigidity and is resistant against erosion from abrasive materials.



# FINISH MACHINING VALVE SEAT AND GUIDE

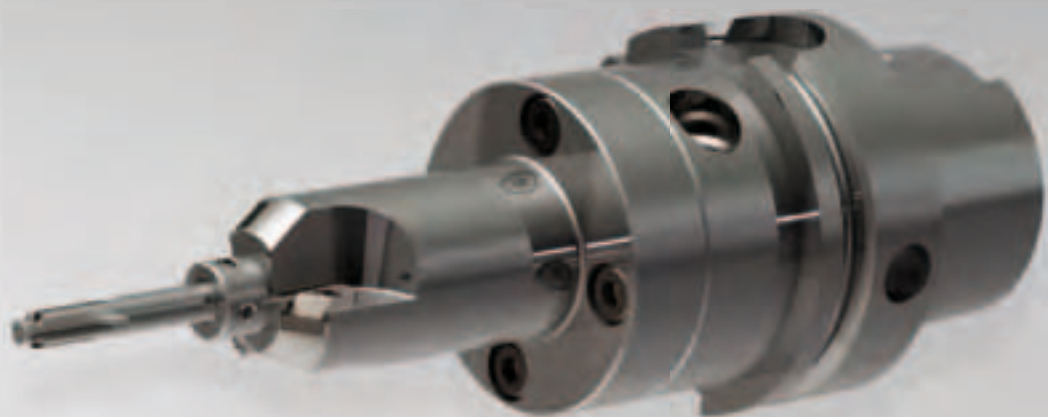

# MOTOR Cylinder head

01

## CONTROL CUTS

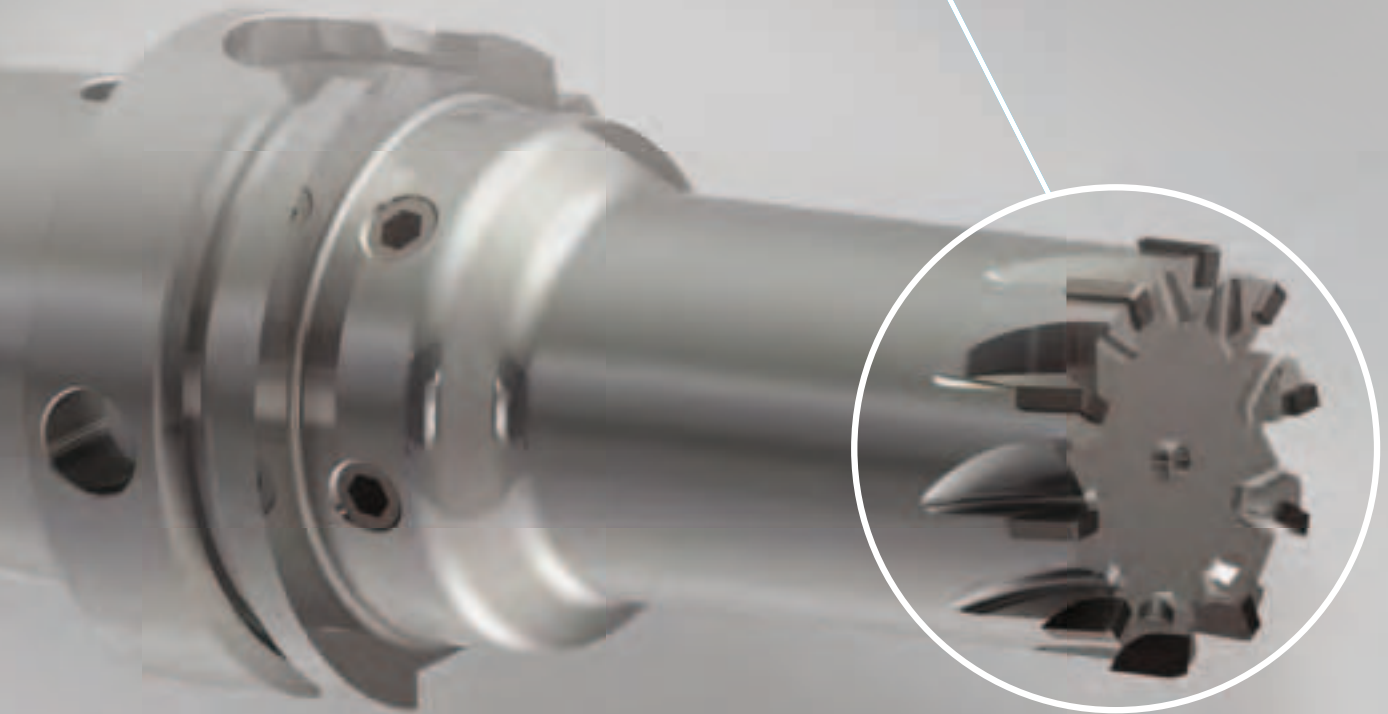

# HVA MACHINING

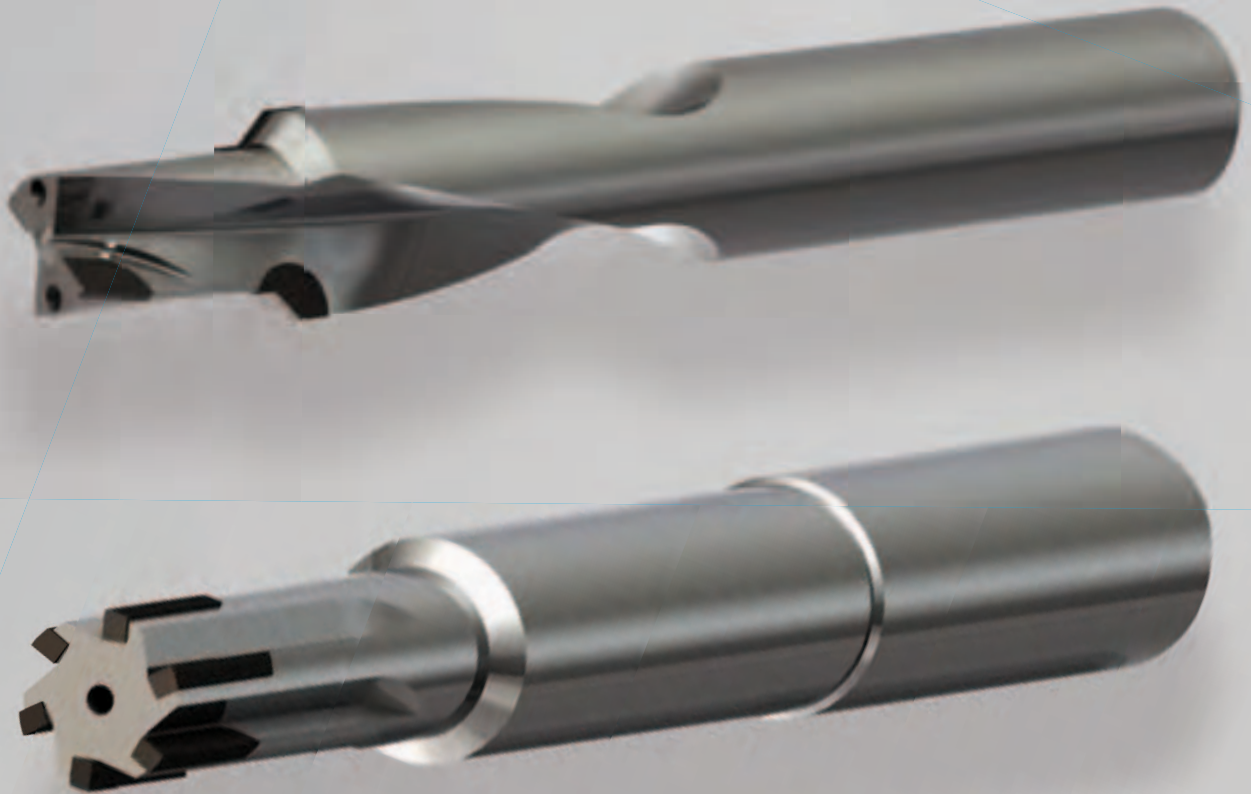

The specifically developed cutting edge geometry provides high accuracy, short cycle times and high feed rates at a consistent quality.

# SPRING SEAT TOOL

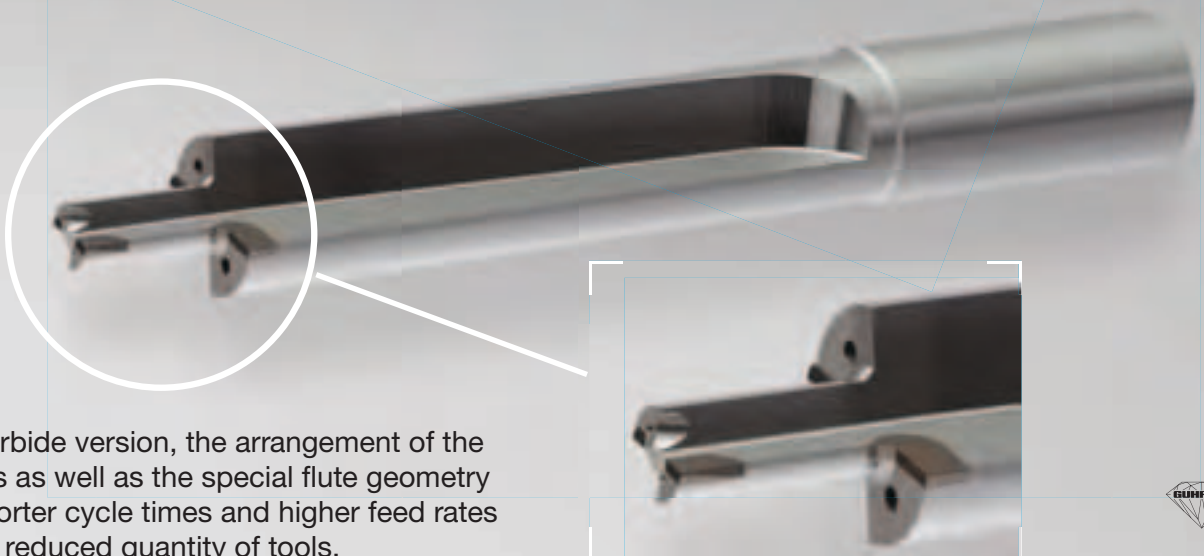

The solid carbide version, the arrangement of the coolant exits as well as the special flute geometry achieves shorter cycle times and higher feed rates – this with a reduced quantity of tools.

# MOTOR Cylinder head High Speed Tooling (HST)

## INJECTOR BORE DRILL

Perfect chip evacuation is guaranteed thanks to the arrangement of the cutting edges and chip chambers.

Several ducts optimally evacuate chips of different diameters.

This design is therefore optimally suited for drilling into the solid despite the stepped diameter increments.

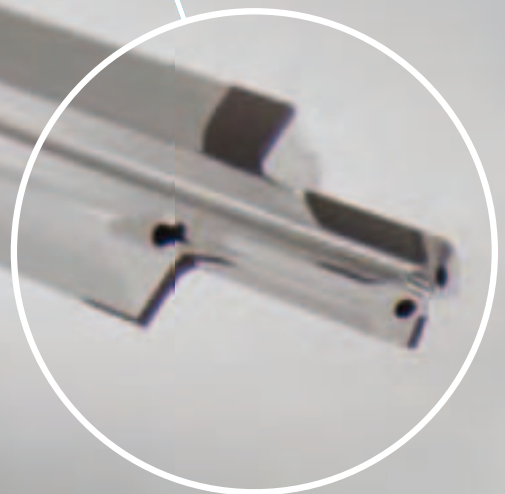

# CAMSHAFT KEYWAY

The application of a spiral solid carbide shank neck guarantees not only rigidity but also perfect guidance.  
The cutting edge diameter can be re-adjusted via expansion screw.



# HVA MACHINING



# MOTOR Cylinder head High Speed Tooling (HST)

## INLET AND OUTLET CHAMBER AND PRE-MACHINING VALVE SEAT BORE

The intelligent cutting edge arrangement and sophisticated system for chip evacuation combines several operating steps.  
A highly accurate machining solution combines roughing and finishing with one tool.

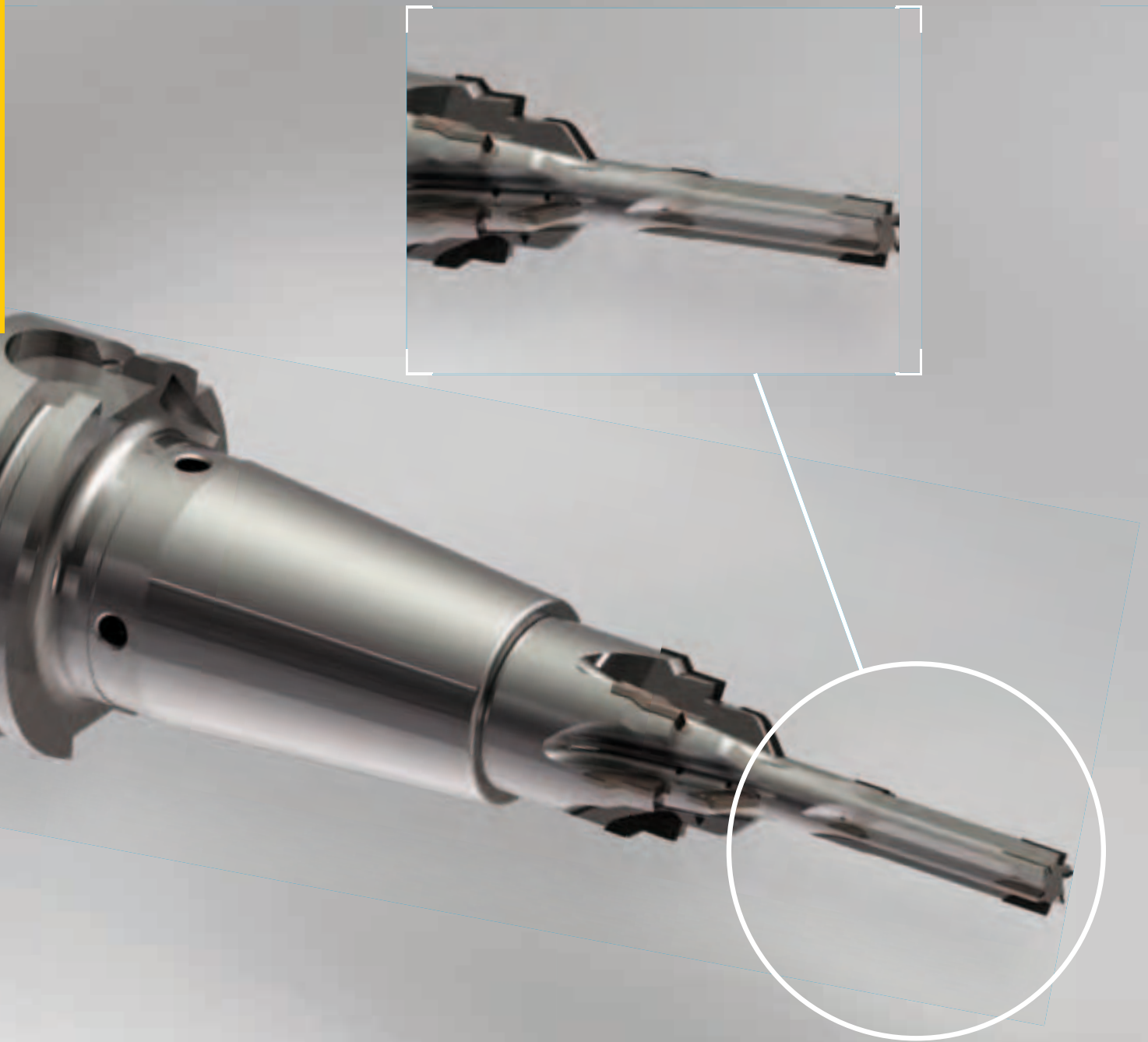

# FASTENING BORE

Very high feed rates can be achieved with process reliability thanks to the optimised chip space geometry.



# SPARK PLUG BORE



# MOTOR





# CYLINDER HEAD COVER



# MOTOR Cylinder head cover

## COMBINATION TOOL FOR CAMSHAFT BEARING KEYWAY

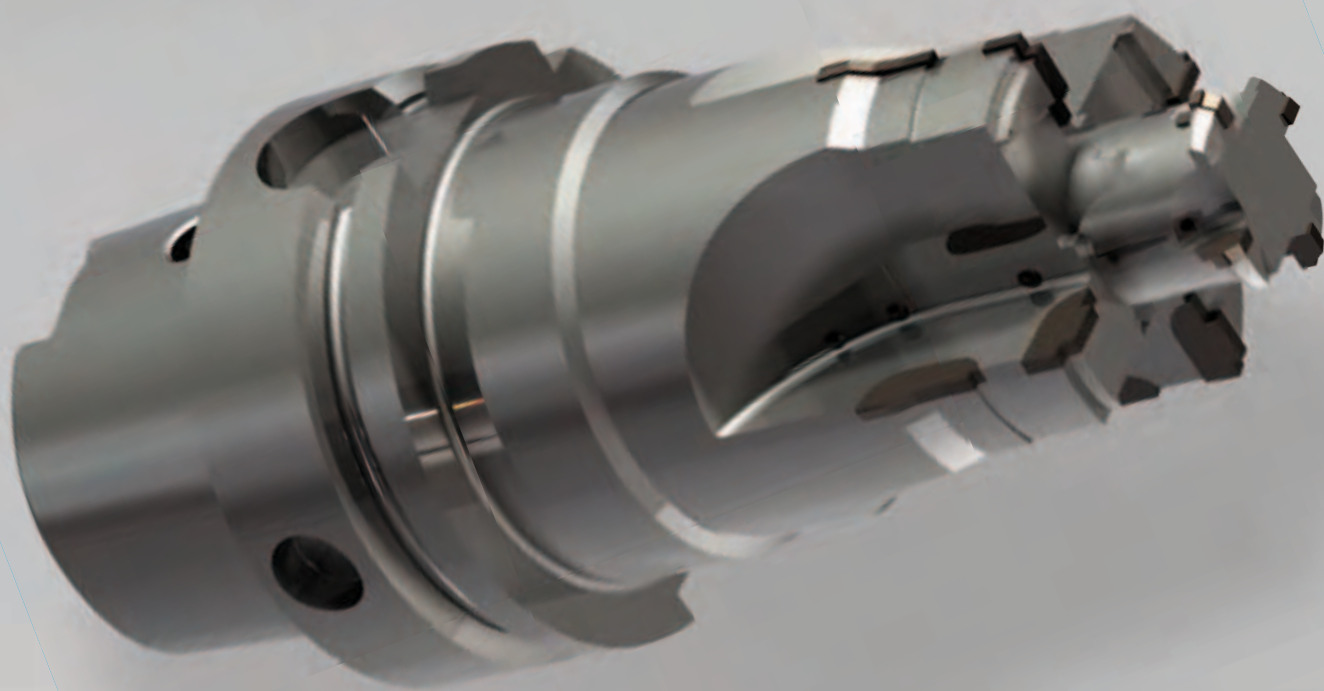

# CONNECTION BORE



# OIL DIPSTICK BORE



# MOTOR



# CRANKCASE



# MOTOR Crankcase

# 01

## RELIEF GROOVE

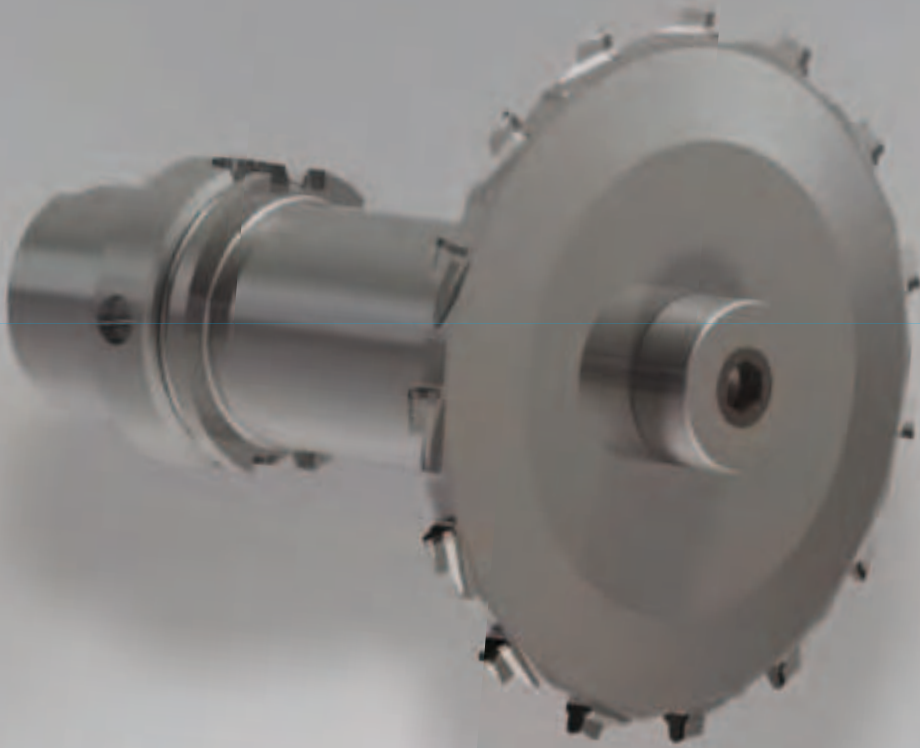

## SEALING GROOVE MILLING CUTTER Ø 2 MM

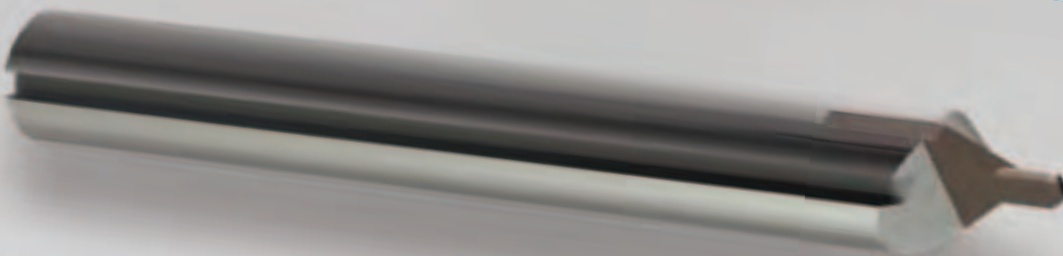

# THRUST BEARING

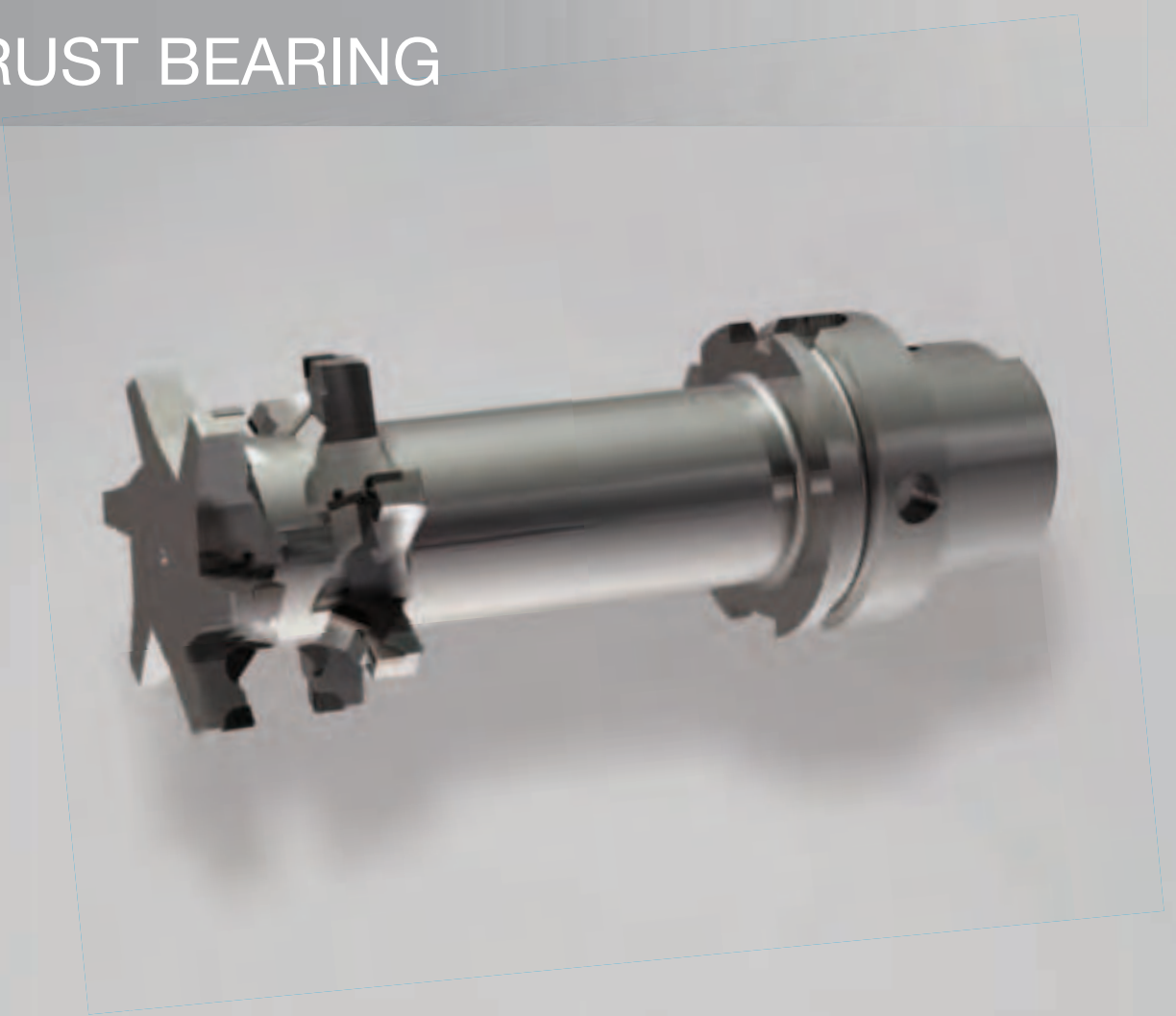

# MILLING – CONTROL CUTS



# MOTOR Crankcase

# 01

## PULSATION WINDOW

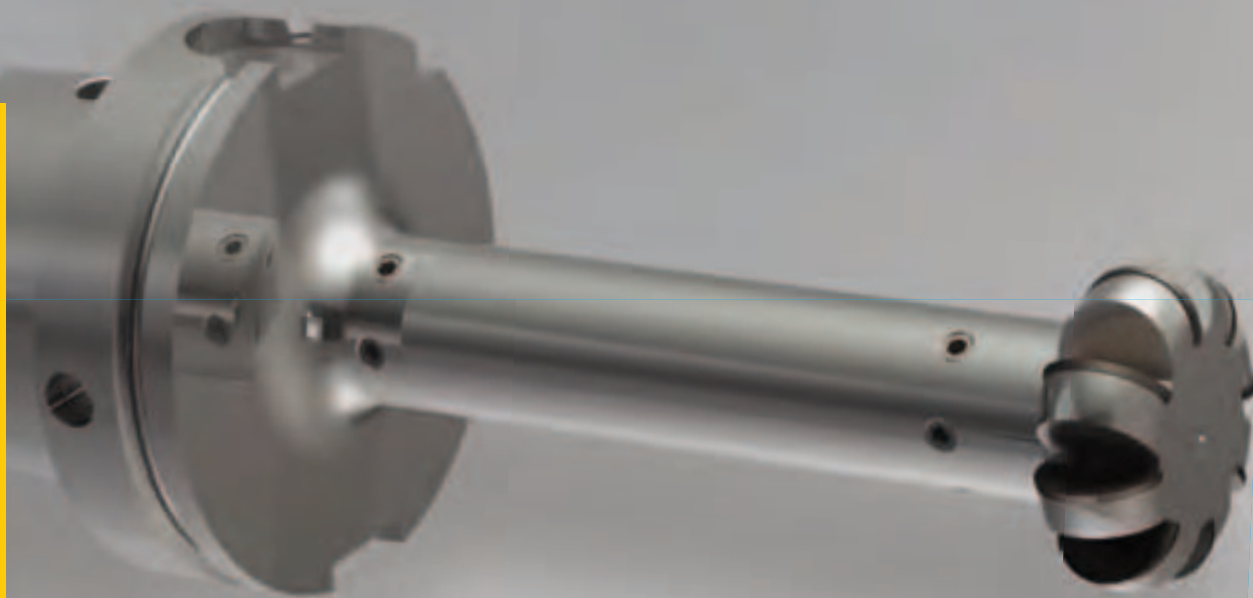

## PRE-MACHINING BALANCE SHAFT BORE

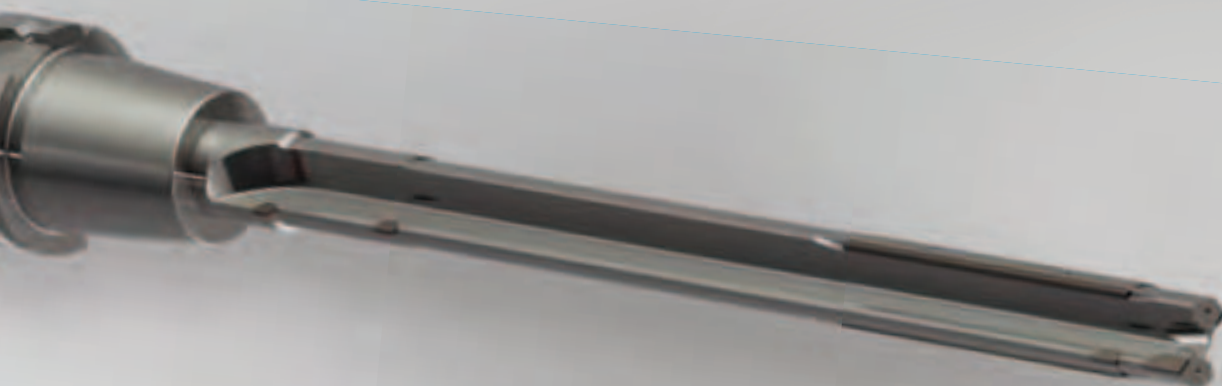



# WATER JACKET BORE

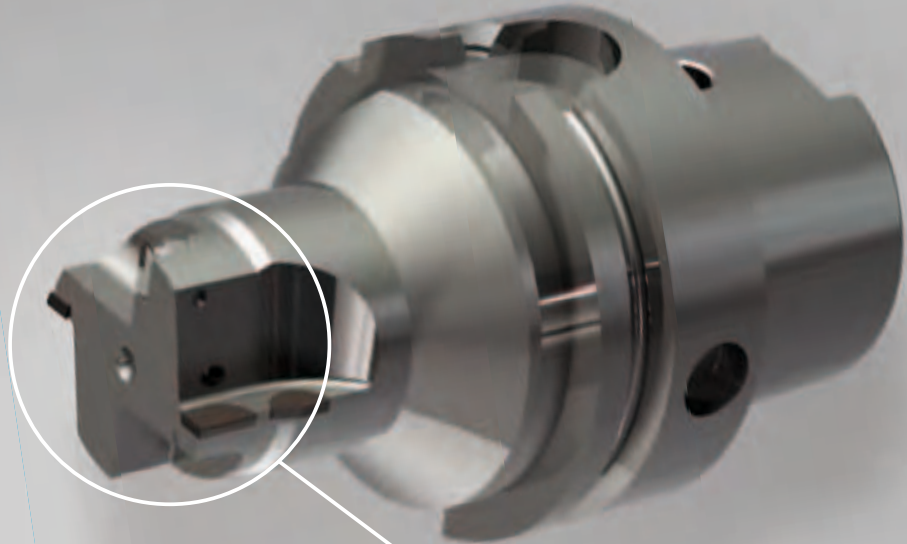

The required hole roughness is achieved via threaded wedge adjustment (TWA).

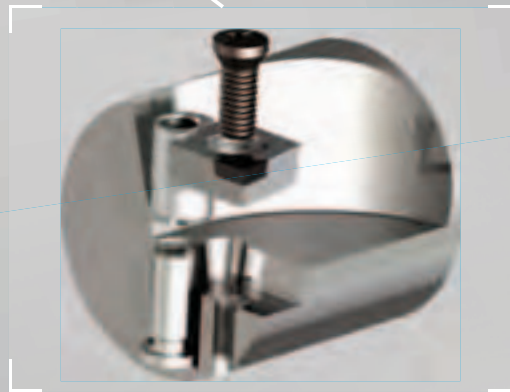

# THERMOSTAT BORE

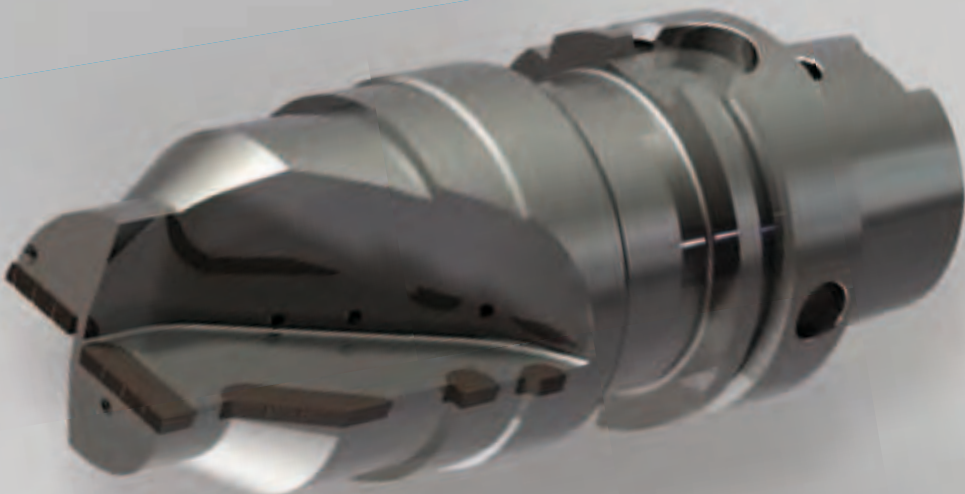

# DRIVE

## ACCURATE MACHINING

Independent of diameter and complexity all PCD tools from Guhring meet the highest demands on reliability and accuracy. This is especially important for machining the transmission. When being machined the thin-walled material of the transmission housing is liable to suffer vibrations making the machining process more difficult and endangering the accuracy. To counteract vibration, PCD tools possess special cutting edge properties – for guaranteed process reliable machining.



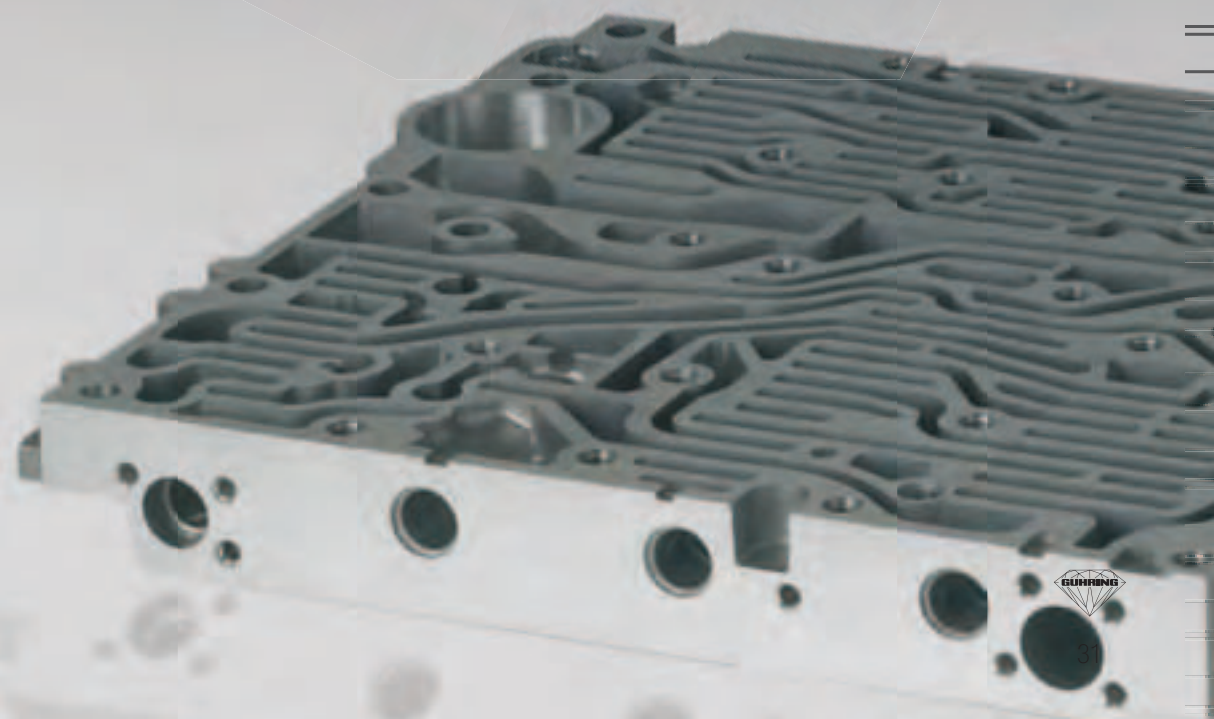
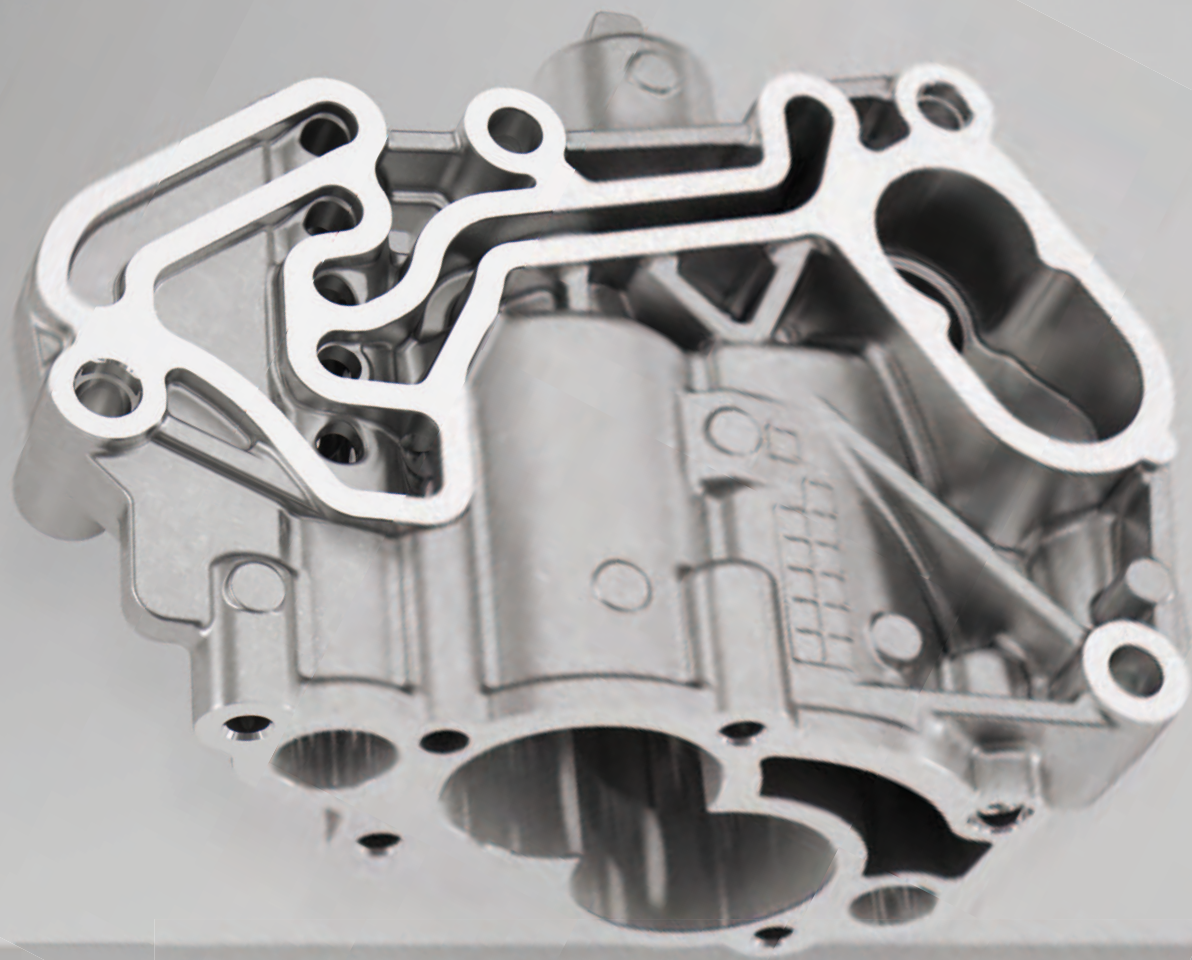

## SAFETY CUT BELL HOUSING

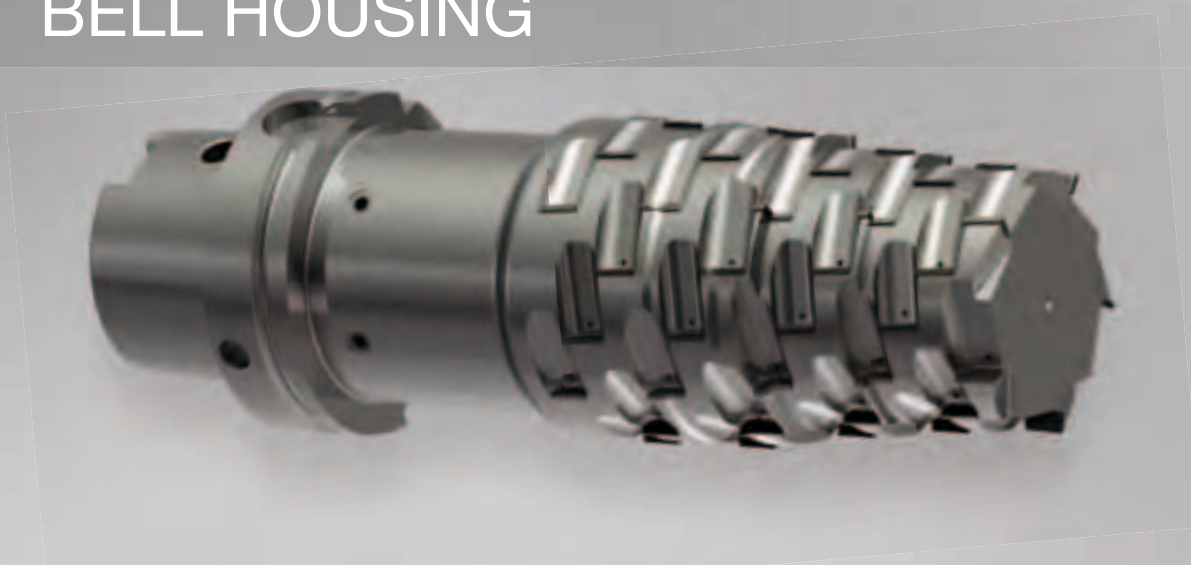

## MAIN BEARING BORE FRONT AND REAR

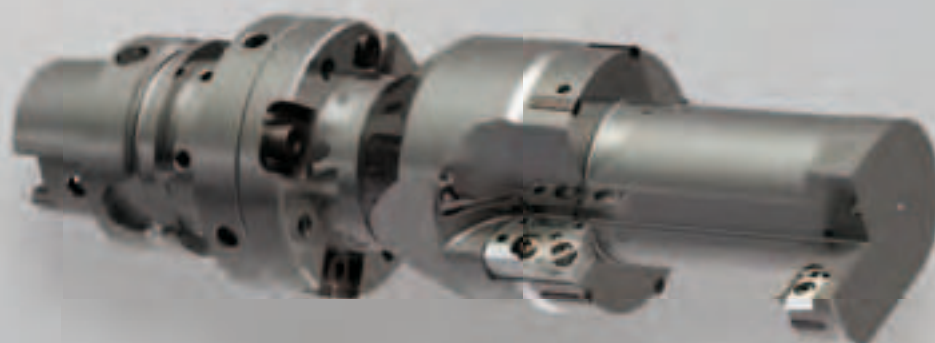

## PINTLE MACHINING



# AUXILIARY DRIVE



# OUTPUT SIDE SEALING GROOVE



# COMBINATION DRILLING, REAMING, MILLING



# DRIVE Valve housing

02

## PILOT DRILLING



## PRE-MACHINING



# FINISH MACHINING



# DRIVE Pump housing

# 02

## FINISH MACHINING MAIN OIL BORE



## GROOVE MAIN OIL BORE





# OVER TURNING JOURNAL, FINISH MACHINING BEARING BORE



# PRE-MACHINING MAIN OIL BORE

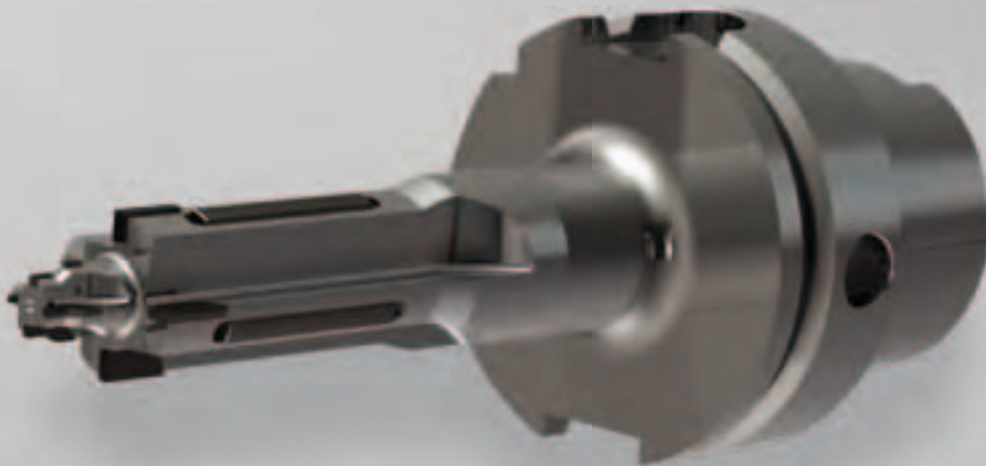

# CONTROL BORE



# AXLES AND S

## INNOVATIVE SOLUTIONS FOR SPECIAL REQUIREMENTS

Automotive components relating to axles and steering are kinetically exposed to high stresses. The quality and accuracy requirements when machining them is accordingly high. Aluminium wrought alloys are especially tough and soft and are therefore applied to withstand these stresses and to ensure a certain flexibility. However, when machining aluminium lengthy chips are created. Guhring's PCD tools guarantee an optimal chip breaker ability and, therefore, a better swarf evacuation.



# STEERING



# AXLES AND STEERING

## Wheel carrier

---

### DRILLING MAIN BORE



### MAIN BORE THROUGH DRILLING AND PARALLEL LANDS

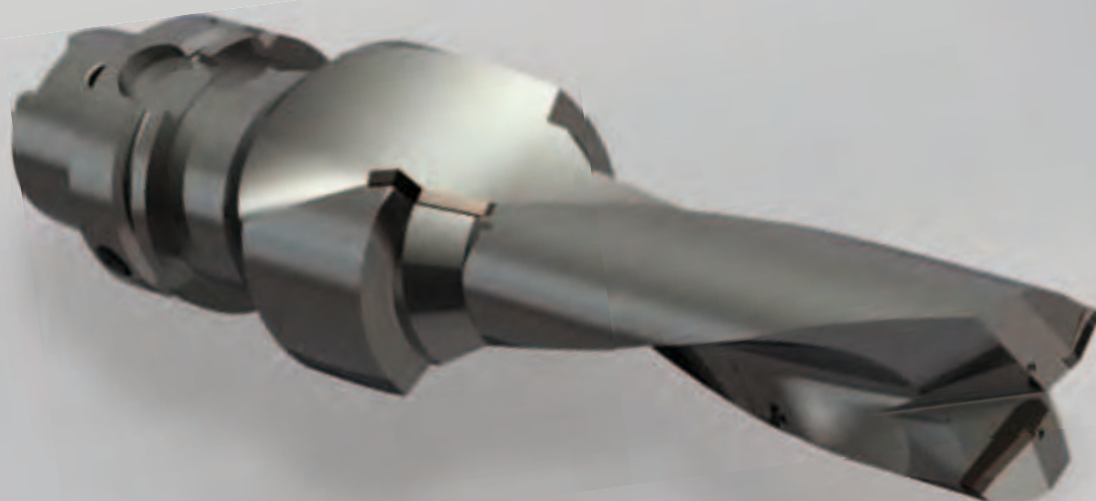

# REAMING MAIN BORE



# REAMING AND MILLING HUB BORES



# CONTROL CUTS



# AXLES AND STEERING

## Axle uprights

---

### SPHERICAL BORE



### SPHERICAL MILLING CUTTER



# MAIN BORE



# BORE FOR RUBBER BUSHING

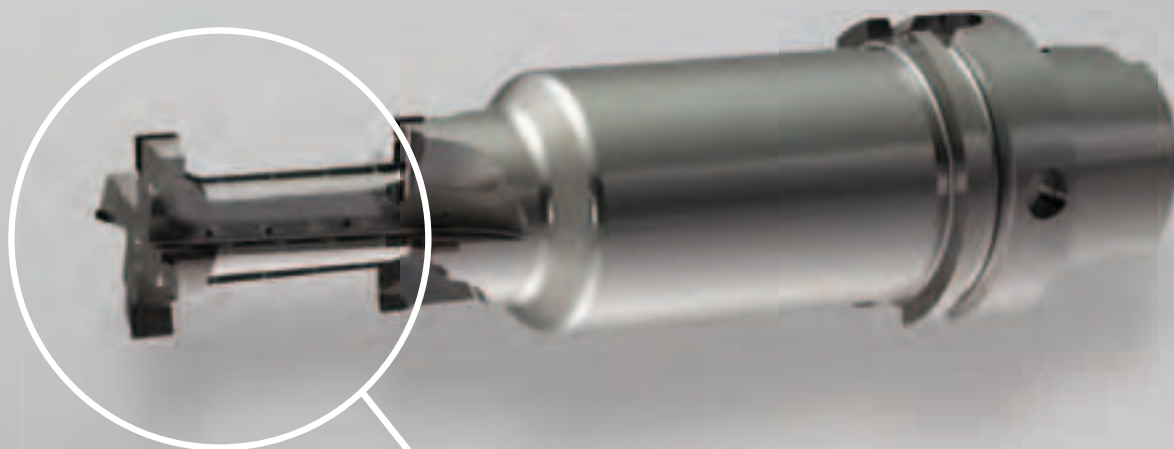

Drilling, profile and surface milling



# AXLES AND STEERING

## Steering column

---

03

### SEAL CONNECTION



### SERVO GEAR UNIT BORE





# MAIN BORE



# PINION BORE

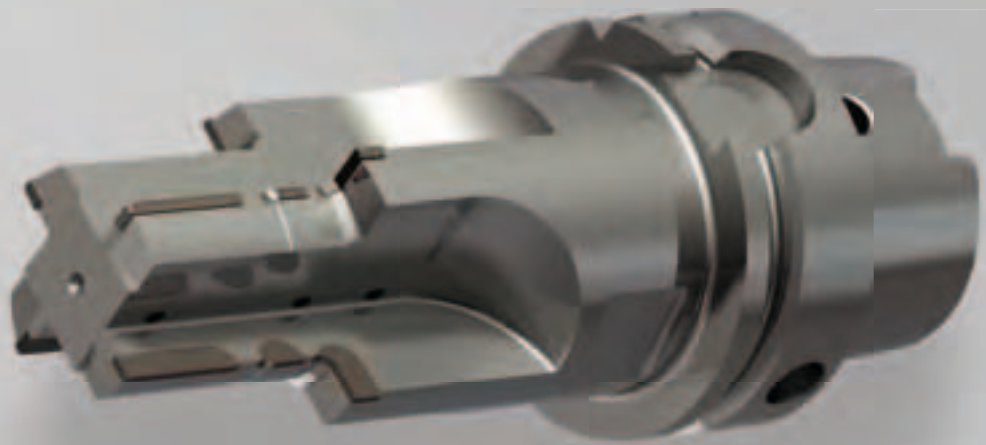

# STEERING SPINDLE BORE



# AXLES AND STEERING

## Joint machining

---

### BALL NOSED MILLING CUTTERS

In order to provide the customer with the best possible solution for his machining task, Guhring applies a special software to calculate the tool geometries: The software assists in calculating an application specific tooling solution from information regarding forms and tolerances.



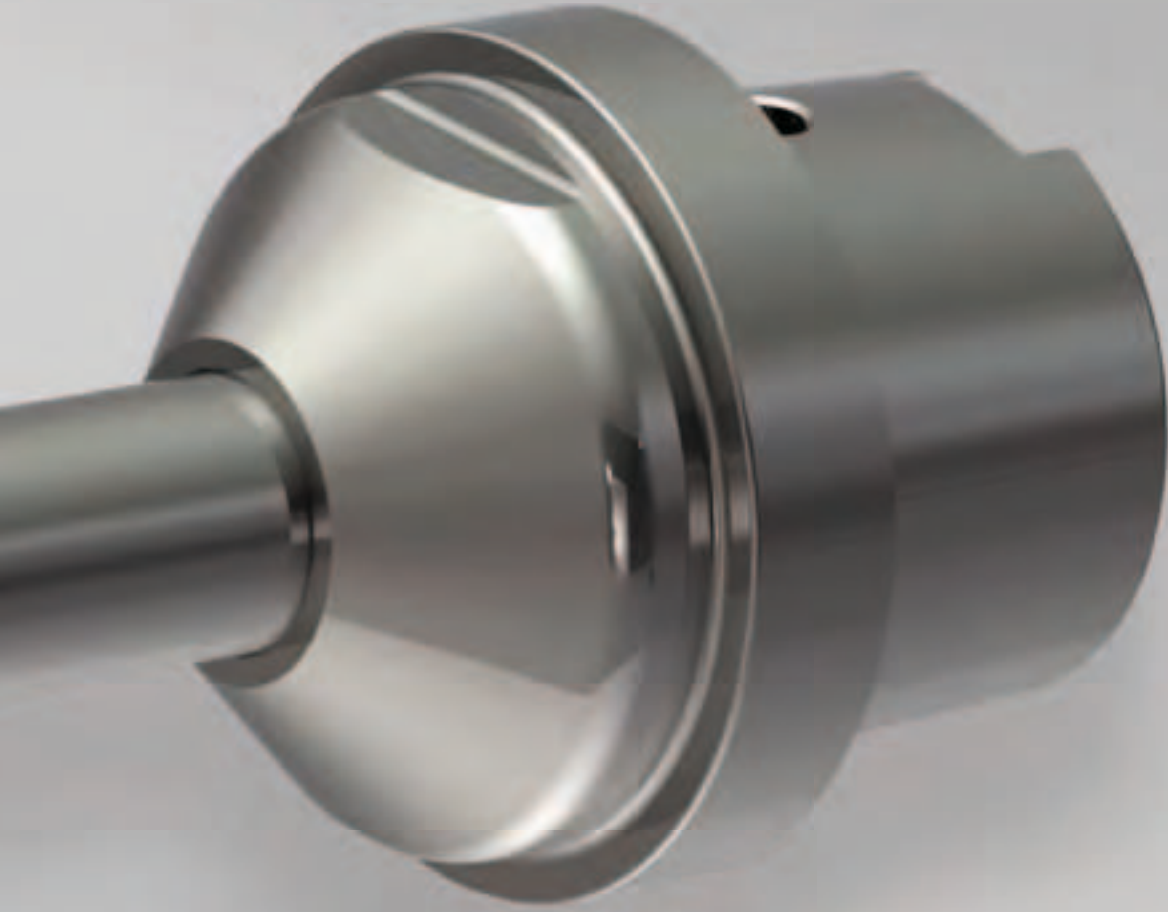

# BRAKES

SAFETY THANKS  
TO HIGHEST ACCURACY



Components of the braking system in automotive manufacturing are exposed to particularly heavy loads. They must consistently withstand the effect of high forces and must not show any signs of wear. For these components therefore especially wear-resistant and robust materials are applied – that are again difficult to machine. Where cast iron was previously applied, today aluminium is almost exclusively used as workpiece material in order to manufacture lighter and therefore more energy efficient components. These tough materials can be perfectly machined with PCD tools from Guhring. They guarantee the machining of safety relevant components to the highest accuracy.



# BRAKES Brake caliper

# 04

## PROTECTIVE CAP COLLAR

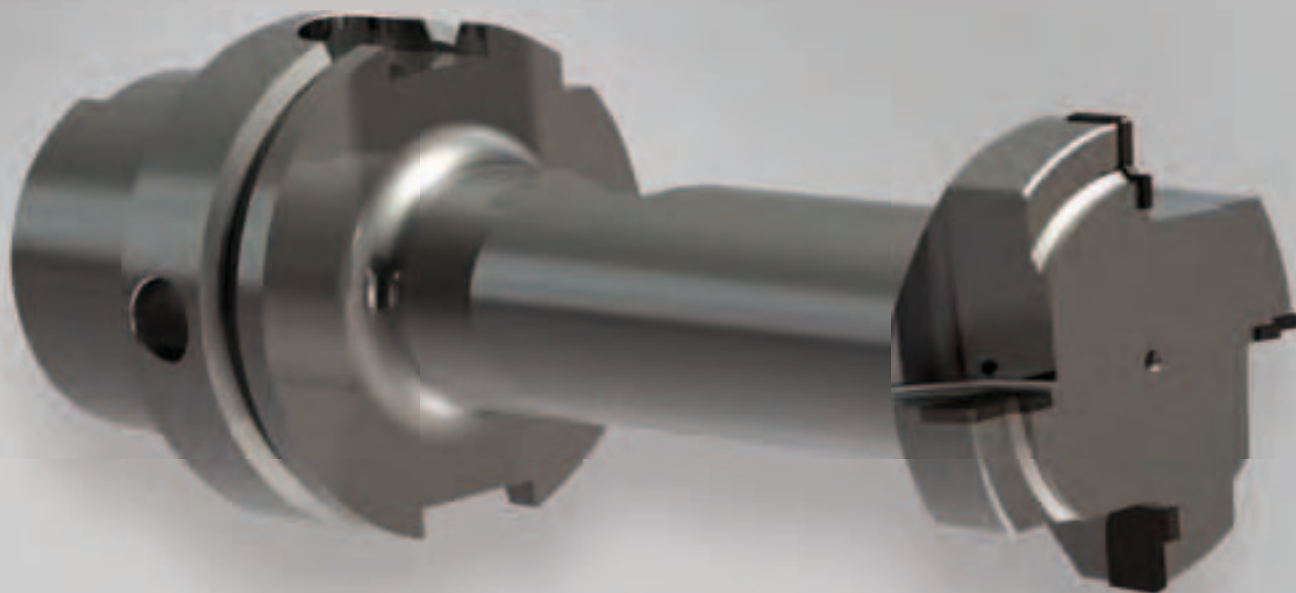

## SEAL RING GROOVE



## SPRING CAP BORE



## FASTENING SURFACES

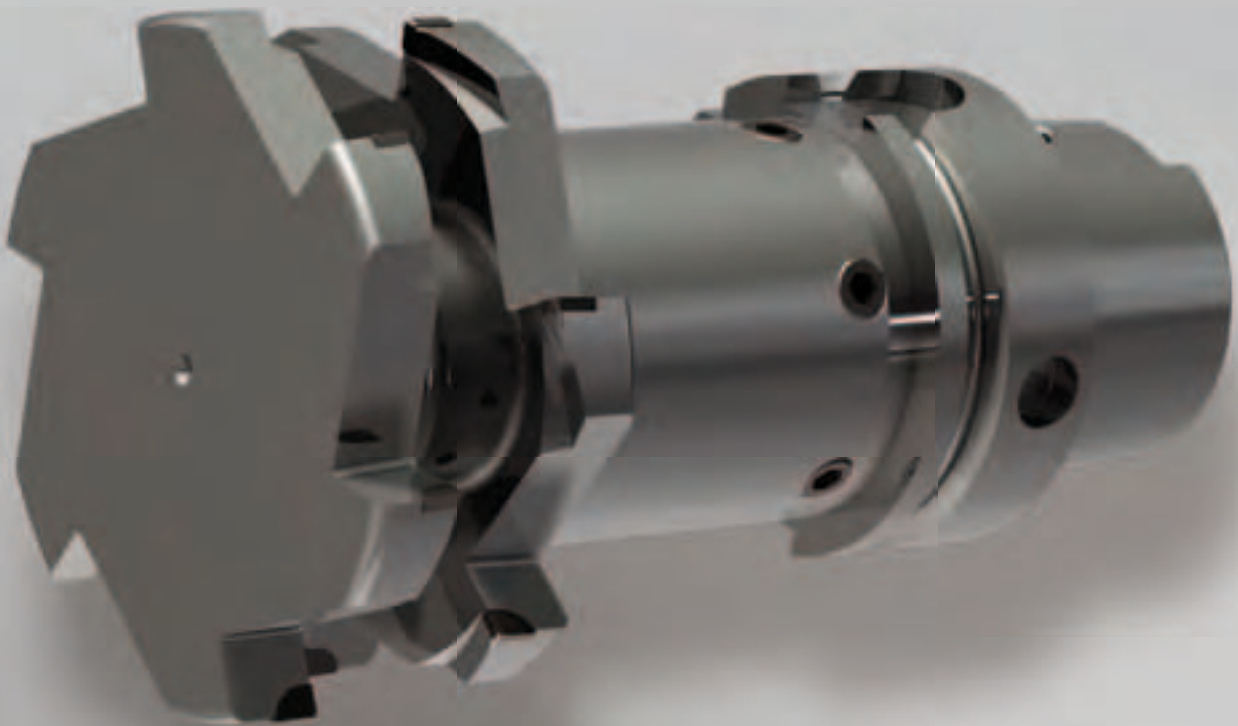

# BRAKES Brake cylinder

04

## MAIN BORE

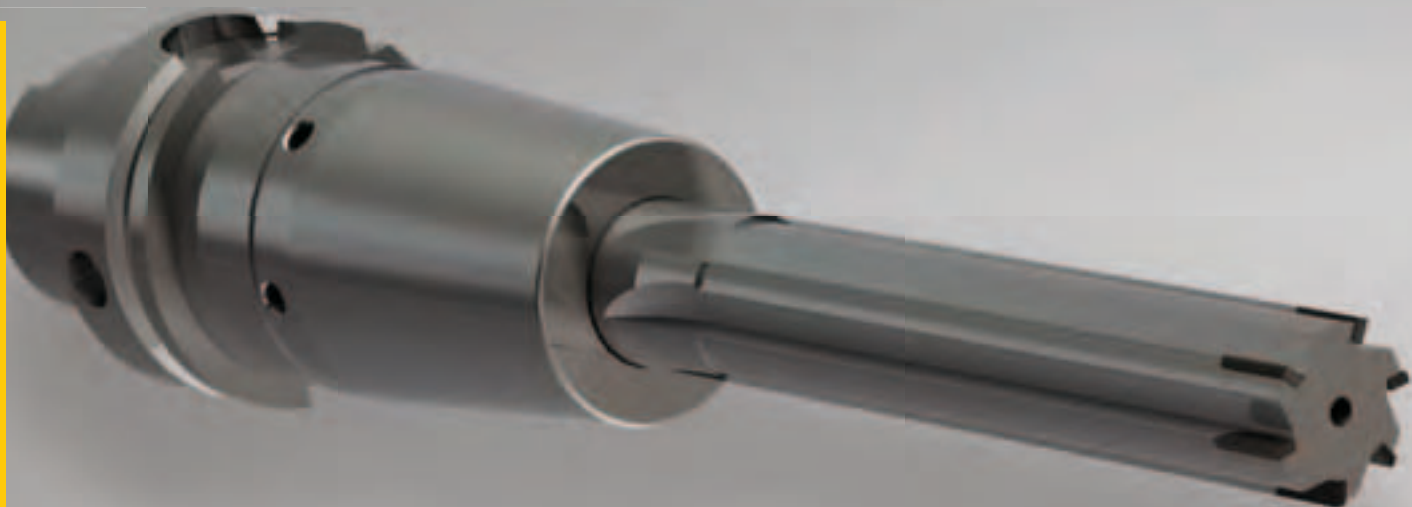

## OIL INLET CONNECTION

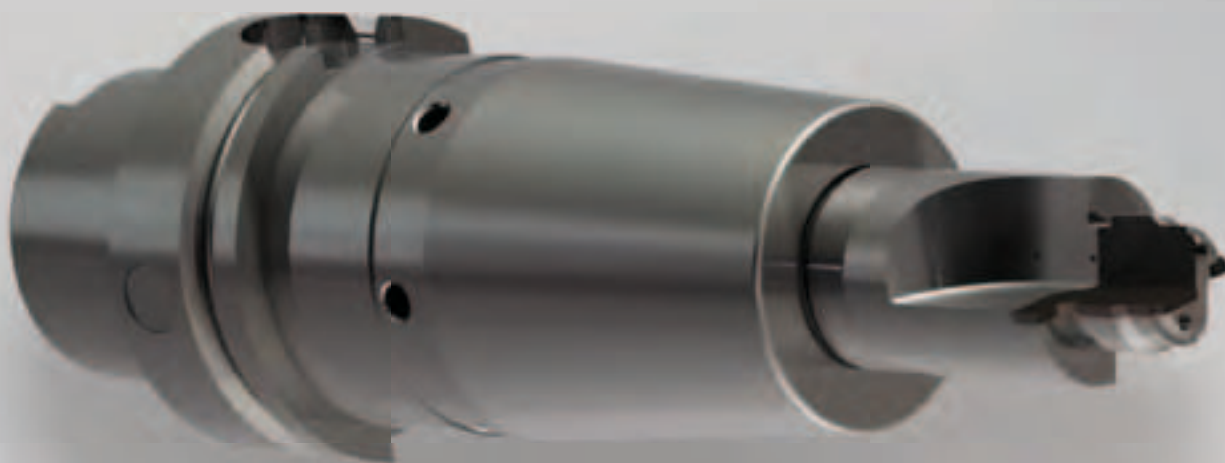



# PILOT DRILLING AND MAIN CONNECTION

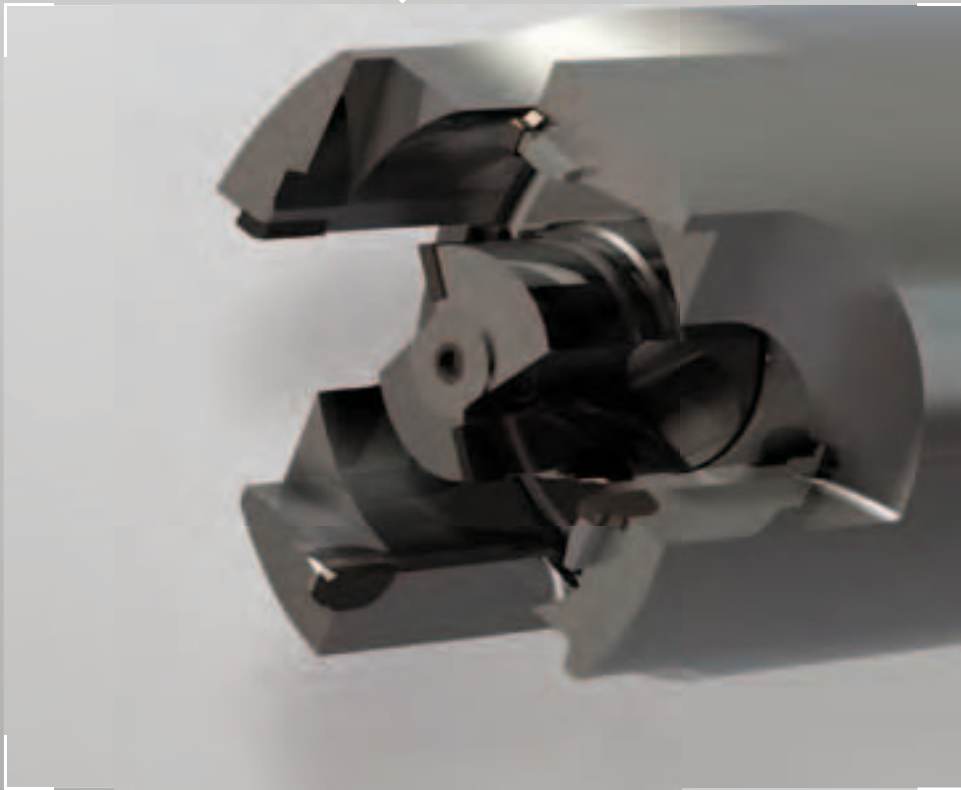
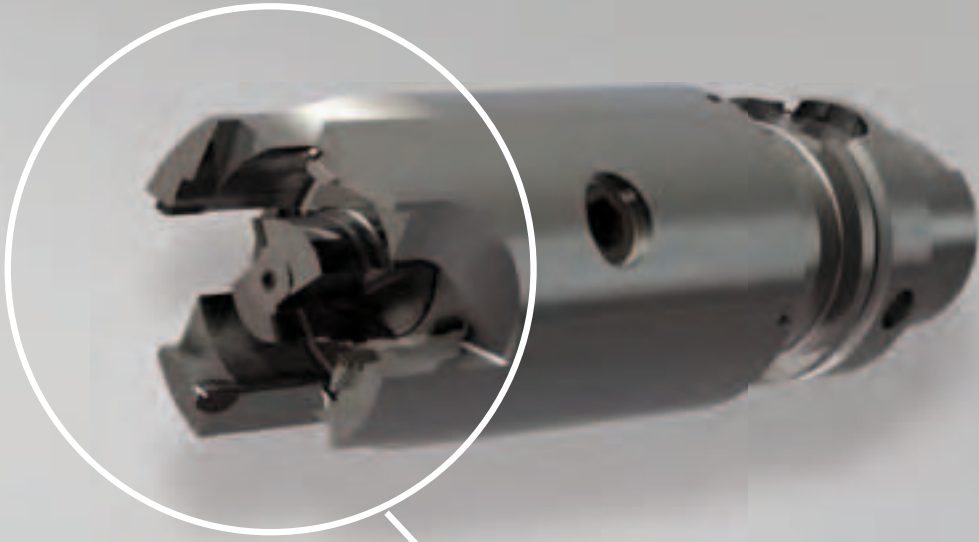

combined internal and external machining

# BRAKES Brake disc

# 04

## SOLID CBN INDEXABLE INSERTS

Machining:	brake discs/rolls
Material to be machined:	GG/hardened steels
Holding in:	clamping holder
Cooling:	soluble oil or dry machining



8 Cutting edge corners



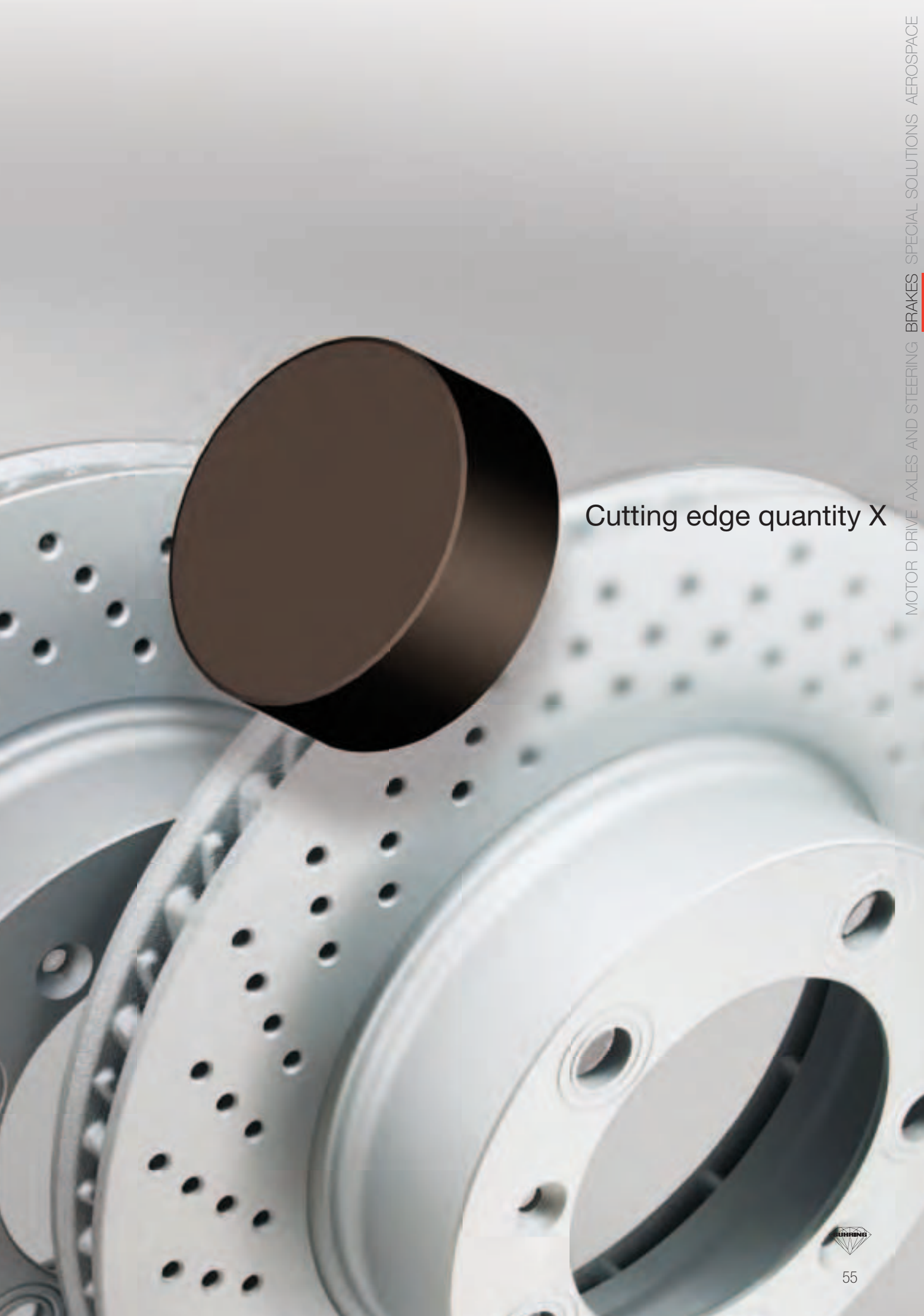

Cutting edge quantity X



# SPECIAL SOLUTIONS FOR INDIVIDUAL REQUIREMENTS

## SPECIAL SOLUTIONS FOR INDIVIDUAL REQUIREMENTS

Whether simultaneous machining of internal and external contours, the combination of several operating steps or special holes where no chips are allowed to enter inside the workpiece: For any machining task Guhring has an individual solution.

Complex tools from Guhring combine multiple machining steps into one tooling solution and thus save tools and tool change time.

Furthermore, Guhring has developed innovative tools in order to enable the use of PCD cutting edges for applications that so far this high-performance material has not been available for, as for example, PCD head-tipped reamers from  $\varnothing$  2.5 mm.

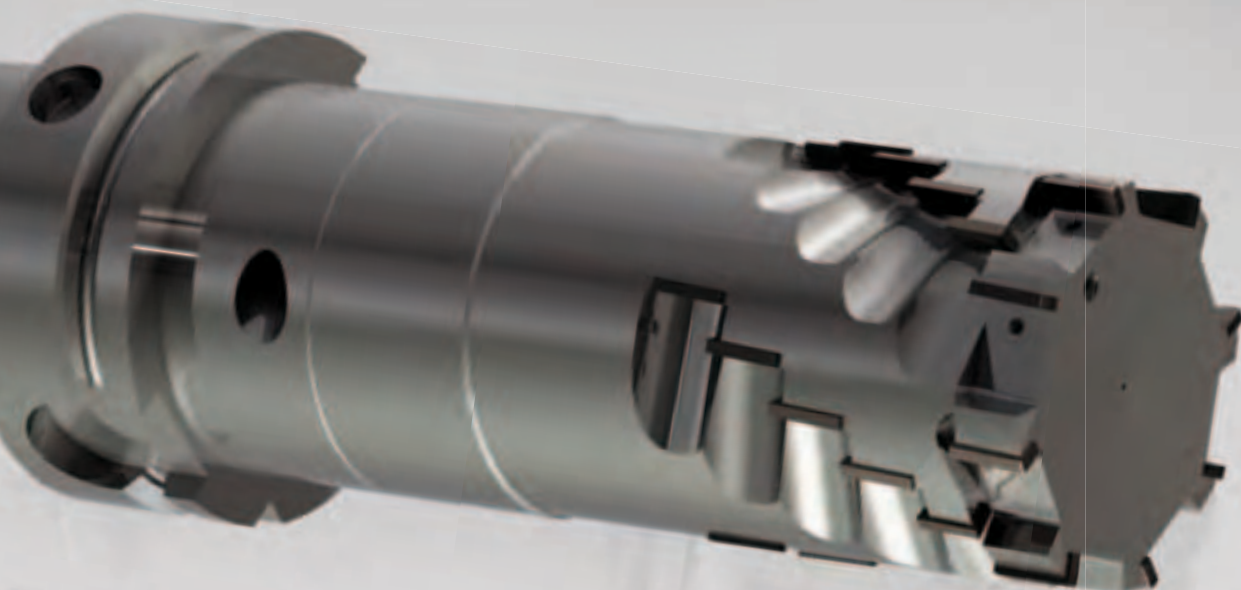

# SOLUTIONS



# SPECIAL SOLUTIONS

05

## CONTOUR GANG HOB



Form inserts can be individually replaced.

## THREAD MILLING CUTTER



# BELL MILLING CUTTER WITH EXTERNAL RING



Bell milling cutter with external ring for rigidity:  
Ensuring maximum speed and quality.

# WATER JACKET BALL

The risk of blocking the hole with chips is drastically minimised thanks to specially formed wedges and optimal cooling.

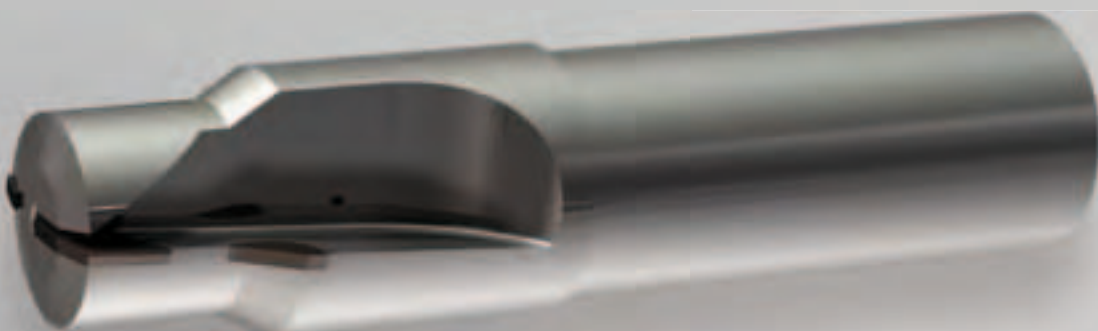

# SPECIAL SOLUTIONS

## INTERNAL AND EXTERNAL MACHINING

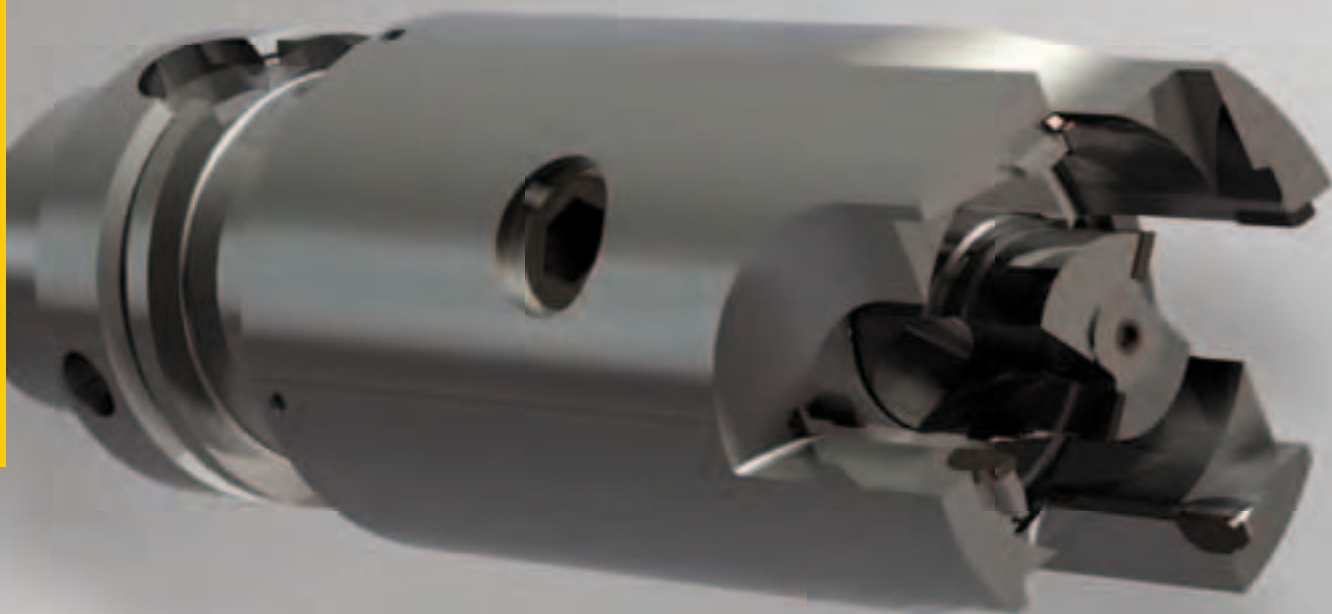



# REAMERS COMBINED WITH INSERTION MILLING CUTTERS

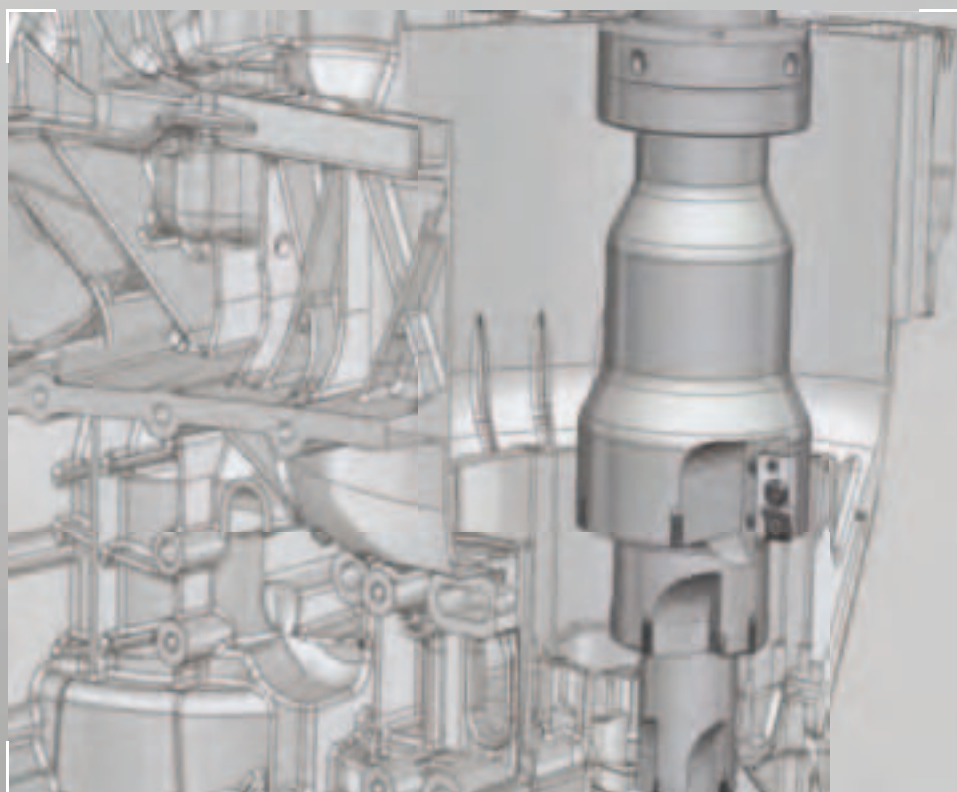

# SPECIAL SOLUTIONS

05

## MILLING CUTTER WITH INTERCHANGEABLE HEAD

The two-piece milling cutter consists of an interchangeable head and a chuck. Instead of replacing the complete milling cutter, the head can be replaced in seconds when required.

A locating pin prevents the cutting edges of the milling head coming into contact with the basic body and the risk of edge damage. Accurate concentricity is ensured thanks to axial and radial adjustment as well as the extreme clamping force. Tool and workpiece wear is minimised.

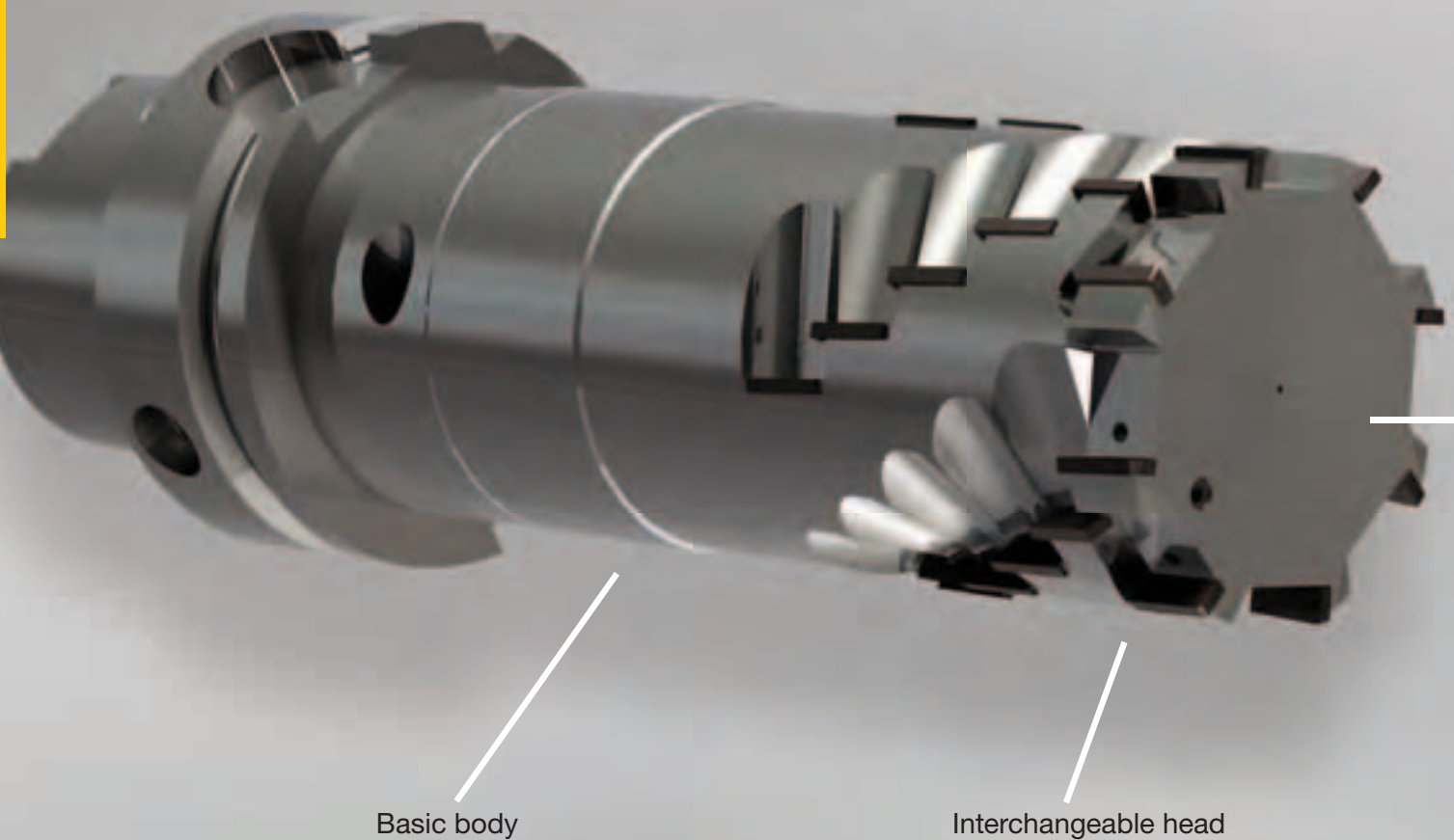

Possible from Ø 32 mm to Ø 100 mm



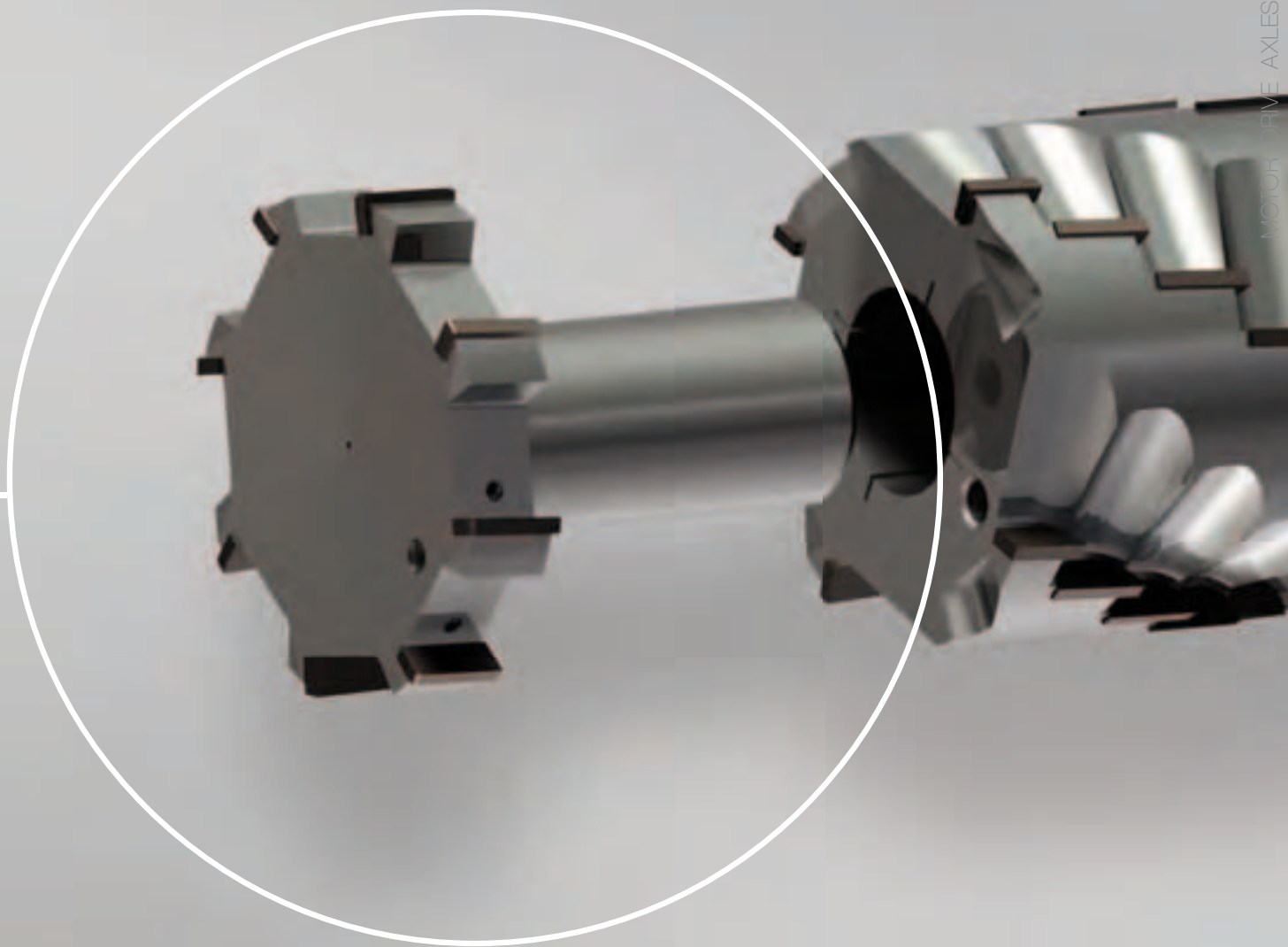

The head performs the main machining function.



# SPECIAL SOLUTIONS

05

## PCD/CBN REAMERS



# PCD/CBN reamers: Small diameters with multiple cutting edges

Up to now, the miniaturisation of multi-fluted reamers with PCD or CBN cutting edges has set the manufacturers difficult boundaries. However, these have now been crossed by Guhring and makes the machining of small diameters possible with the highest accuracy ( $\geq$  IT6) and a large number of cutting edges.

With immediate effect, Guhring now supplies PCD- or CBN-tipped reamers from

- **Ø 2,5 mm with 4 cutting edges**
- **Ø 3,8 mm with 6 cutting edges**

For the machining of blind holes the tools have a central coolant duct. The reamers for the machining of through holes have the coolant ducts exiting parallel to the cutting edge. This way, even in the smallest holes an optimal supply of coolant to the cutting edges with conventional cooling as well as with minimal quantity lubrication and an effective evacuation of the chips from the hole is ensured.

The combination of the small diameters, the large number of cutting edges and the effective internal cooling offers the user maximum performance for superfinishing small blind hole and through hole diameters with PCD- or CBN-tipped reaming tools!

# AEROSPACE LI CONSTRUCTION

## ECONOMICALLY MACHINING COMPOSITES

Composites, especially the way they are applied in the aerospace industry, convince with highest flexibility, stability, strength and low weight. Their properties, however, are found to have a tendency to delaminate that makes them difficult to machine.

PCD tools prevent the delamination of abrasive materials thanks to their extremely sharp and wear-resistant diamond cutting edges.



# GHTWEIGHT N



# AEROSPACE LIGHTWEIGHT CONSTRUCTION

UPPER-LOWER SHELL MACHINING  
ROUGHING AND FINISHING CUT



COMPRESSION MILLING CUTTER

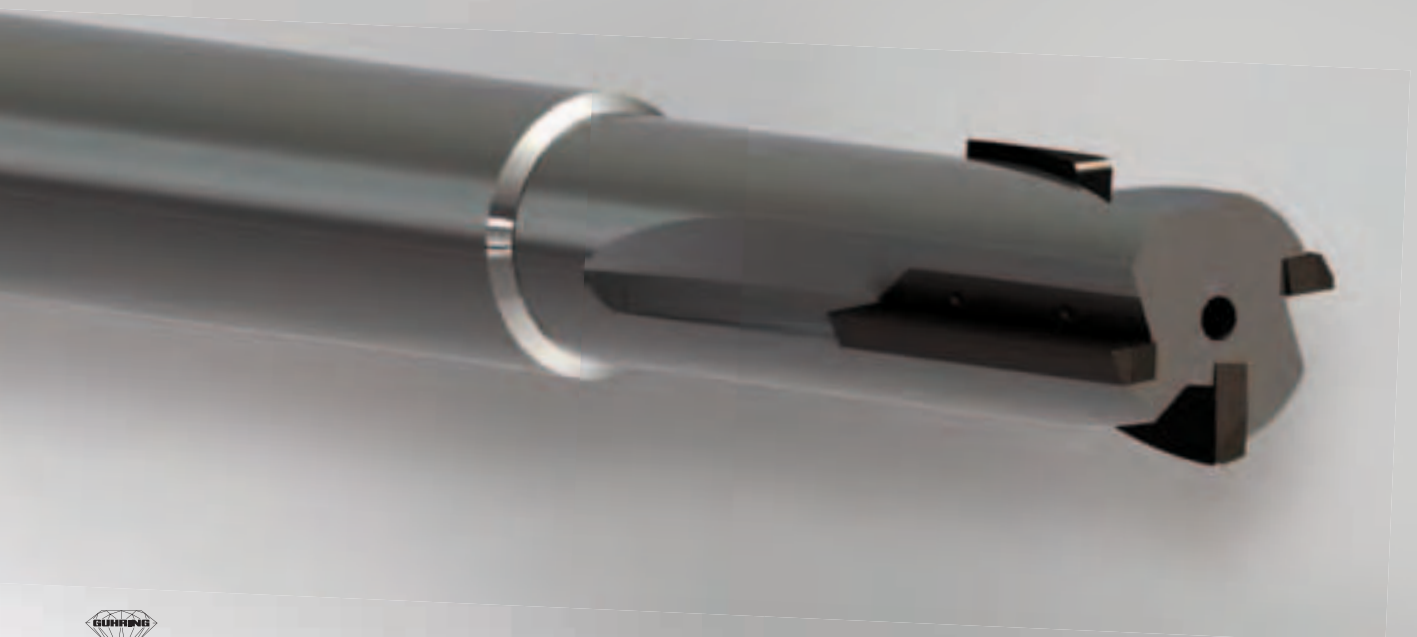



# COUNTERSUNK-HEAD RIVET DRILL

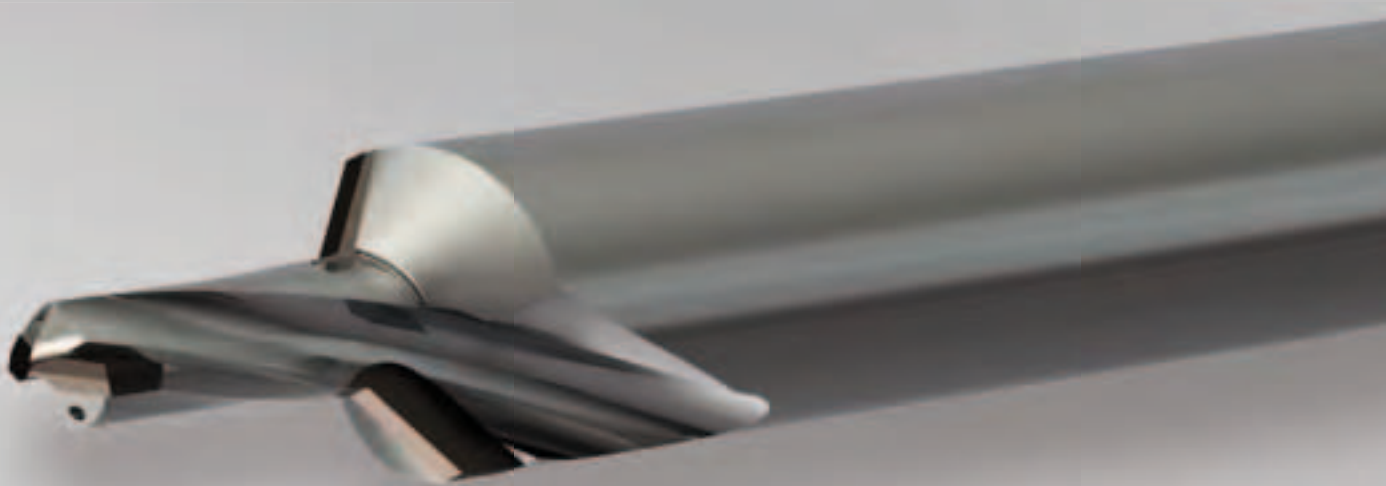

# Slot drills (2-fluted)

**Guhring no.**

**5492**

**Standard**

**Guhring std.**

**Tool material**

**PCD**

**Surface**

**bright**

**Shank design**

**HA**

**Helix**

**0°**

**Cooling**

**axial**

**Discount group**

**110**

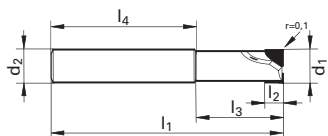

d1	d2	l1	l2	l3	l4	Z	Code no.
mm	mm	mm	mm	mm	mm		
4.000	6.000	51.00	6.00	15.00	36.00	2	4,000
5.000	6.000	51.00	8.00	15.00	36.00	2	5,000
6.000	6.000	57.00	8.00	21.00	36.00	2	6,000
8.000	8.000	63.00	8.00	27.00	36.00	2	8,000
8.000	8.000	63.00	12.00	27.00	36.00	2	8,001
10.000	10.000	72.00	8.00	32.00	40.00	2	10,000
10.000	10.000	72.00	16.00	32.00	40.00	2	10,001
12.000	12.000	83.00	8.00	38.00	45.00	2	12,000
12.000	12.000	83.00	16.00	38.00	45.00	2	12,001
14.000	14.000	83.00	8.00	38.00	45.00	2	14,000
14.000	14.000	83.00	16.00	38.00	45.00	2	14,001
16.000	16.000	100.00	12.00	52.00	48.00	2	16,000
16.000	16.000	100.00	20.00	52.00	48.00	2	16,001
18.000	18.000	100.00	12.00	52.00	48.00	2	18,000
18.000	18.000	100.00	20.00	52.00	48.00	2	18,001
20.000	20.000	100.00	12.00	50.00	50.00	2	20,000
20.000	20.000	100.00	20.00	50.00	50.00	2	20,001

Availability



# Slot drills (2-fluted)

**Guhring no.**

**5493**

**Standard**

**Guhring std.**

**Tool material**

**PCD**

**Surface**

**bright**

**Shank design**

**DZ**

**Helix**

**0°**

**Cooling**

**axial**

**Discount group**

**110**

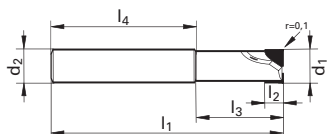

d1	d2	l1	l2	l3	l4	Z	Code no.
mm	mm	mm	mm	mm	mm		
4.000	6.000	70.00	6.00	15.00	55.00	2	4,000
5.000	6.000	70.00	8.00	15.00	55.00	2	5,000
6.000	6.000	75.00	8.00	21.00	54.00	2	6,000
8.000	8.000	100.00	8.00	27.00	73.00	2	8,000
8.000	8.000	100.00	12.00	27.00	73.00	2	8,001
10.000	10.000	100.00	8.00	32.00	68.00	2	10,000
10.000	10.000	100.00	16.00	32.00	68.00	2	10,001
12.000	12.000	100.00	8.00	38.00	62.00	2	12,000
12.000	12.000	100.00	16.00	38.00	62.00	2	12,001
14.000	14.000	100.00	8.00	38.00	62.00	2	14,000
14.000	14.000	100.00	16.00	38.00	62.00	2	14,001
16.000	16.000	150.00	12.00	52.00	98.00	2	16,000
16.000	16.000	150.00	20.00	52.00	98.00	2	16,001
18.000	18.000	125.00	12.00	52.00	73.00	2	18,000
18.000	18.000	125.00	20.00	52.00	73.00	2	18,001
18.000	18.000	150.00	20.00	52.00	98.00	2	18,002
18.000	18.000	150.00	12.00	52.00	98.00	2	18,003
20.000	20.000	150.00	12.00	50.00	100.00	2	20,000
20.000	20.000	150.00	20.00	50.00	100.00	2	20,001

## Availability



# Slot drills (2- and 3-fluted)

**Guhring no.**

**3867**

**Standard**

**Guhring std.**

**Tool material**

**PCD**

**Surface**

**bright**

**Type**

**DL100**

**Shank design**

**HA**

**Helix**

**0°**

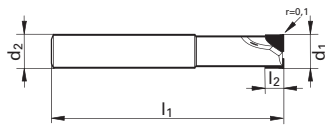

d1	d2	l1	l2	Z	Code no.
inch	inch	inch	inch		
1/4	1/4	2 1/2	3/4	2	6.350
3/8	3/8	3	3/4	2	9.520
1/2	1/2	3	1	2	12.700
3/4	3/4	4	1	2	19.050

**Availability**

on request  
on request  
on request  
on request

**Guhring no.**

**3870**

**Standard**

**Guhring std.**

**Tool material**

**PCD**

**Surface**

**bright**

**Type**

**DL100**

**Shank design**

**HA**

**Helix**

**0°**

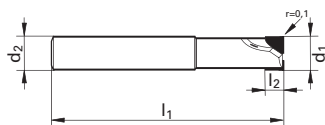

d1	d2	l1	l2	Z	Code no.
inch	inch	inch	inch		
3/8	3/8	3	1/2	3	9.520
1/2	1/2	3	1/2	3	12.700
3/4	3/4	3	1/2	3	19.050
1	1	4	1	3	25.400

**Availability**

on request  
on request  
on request  
on request

# Slot drills (3-fluted)

**Guhring no.**

**5495**

**Standard**

**Guhring std.**

**Tool material**

**PCD**

**Surface**

**bright**

**Shank design**

**HA**

**Helix**

**0°**

**Cooling**

**axial**

**Discount group**

**110**

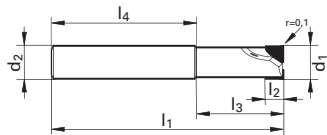

d1	d2	l1	l2	l3	l4	Z	Code no.
mm	mm	mm	mm	mm	mm		
14.000	14.000	83.00	8.00	38.00	45.00	3	14,000
14.000	14.000	83.00	16.00	38.00	45.00	3	14,001
16.000	16.000	100.00	12.00	52.00	48.00	3	16,000
16.000	16.000	100.00	20.00	52.00	48.00	3	16,001
18.000	18.000	100.00	12.00	52.00	48.00	3	18,000
18.000	18.000	100.00	20.00	52.00	48.00	3	18,001
20.000	20.000	100.00	12.00	50.00	50.00	3	20,000
20.000	20.000	100.00	20.00	50.00	50.00	3	20,001

**Availability**



**Artikel-Nr.**

**5496**

**Norm**

**Guhring std.**

**Schneidstoff**

**PCD**

**Oberfläche**

**bright**

**Schaftform**

**DZ**

**Spiralwinkel**

**0°**

**Kühlung**

**axial**

**Rabattgruppe**

**110**

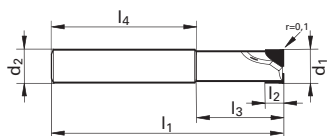

d1	d2	l1	l2	l3	l4	Z	Code no.
mm	mm	mm	mm	mm	mm		
14.000	14.000	100.00	8.00	38.00	62.00	3	14,000
14.000	14.000	100.00	16.00	38.00	62.00	3	14,001
16.000	16.000	150.00	12.00	52.00	98.00	3	16,000
16.000	16.000	150.00	20.00	52.00	98.00	3	16,001
18.000	18.000	150.00	12.00	52.00	98.00	3	18,000
18.000	18.000	150.00	20.00	52.00	98.00	3	18,001
20.000	20.000	150.00	12.00	50.00	100.00	3	20,000
20.000	20.000	150.00	20.00	50.00	100.00	3	20,001

**Availability**



# STANDARD TOOLS AND ISO IN

## HIGH-TECH EX-STOCK

The focus of Guhring's PCD production is customer and application specific special solutions.

Furthermore, standard tools with PCD cutting edges are available with immediate effect for conventional machining tasks or industrial solutions. The ISO-insert program also includes standard PCD inserts as well as short clamping holders for the cost-effective re-tipping of complex tools.

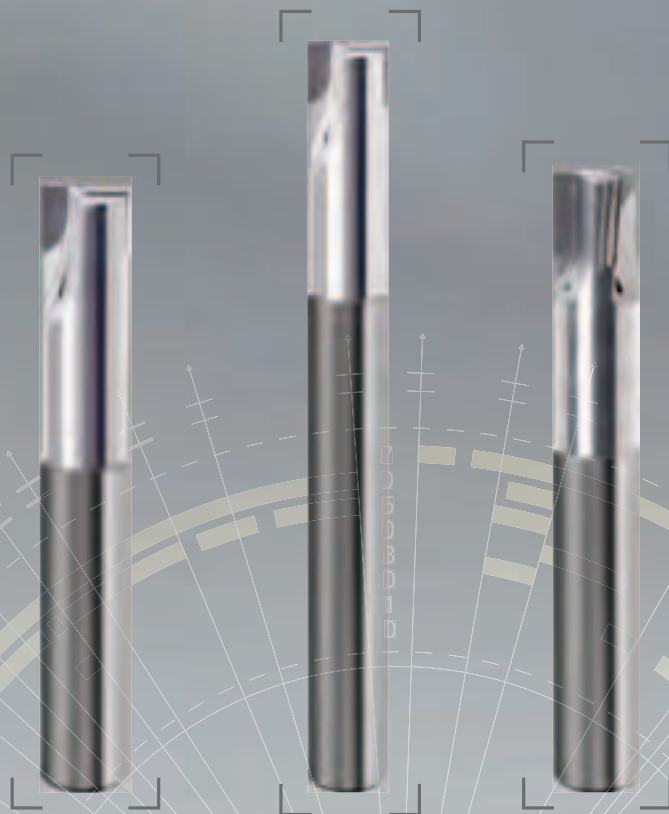

# SERTS







ISO indexable inserts PCD/CBN .....	page	78
ISO inserts for machining valve seat .....	page	87
Short clamping holders KV400.....	page	89
Threaded key adjustment unit .....	page	92
Indexable insert description .....	page	94
Tool materials PCD and CBN .....	page	98
Application recommendations for inserts .....	page	99
Cutting recommendations for inserts .....	page	100
Milling cutters .....	page	102
PF 1000 face milling cutter.....	page	107

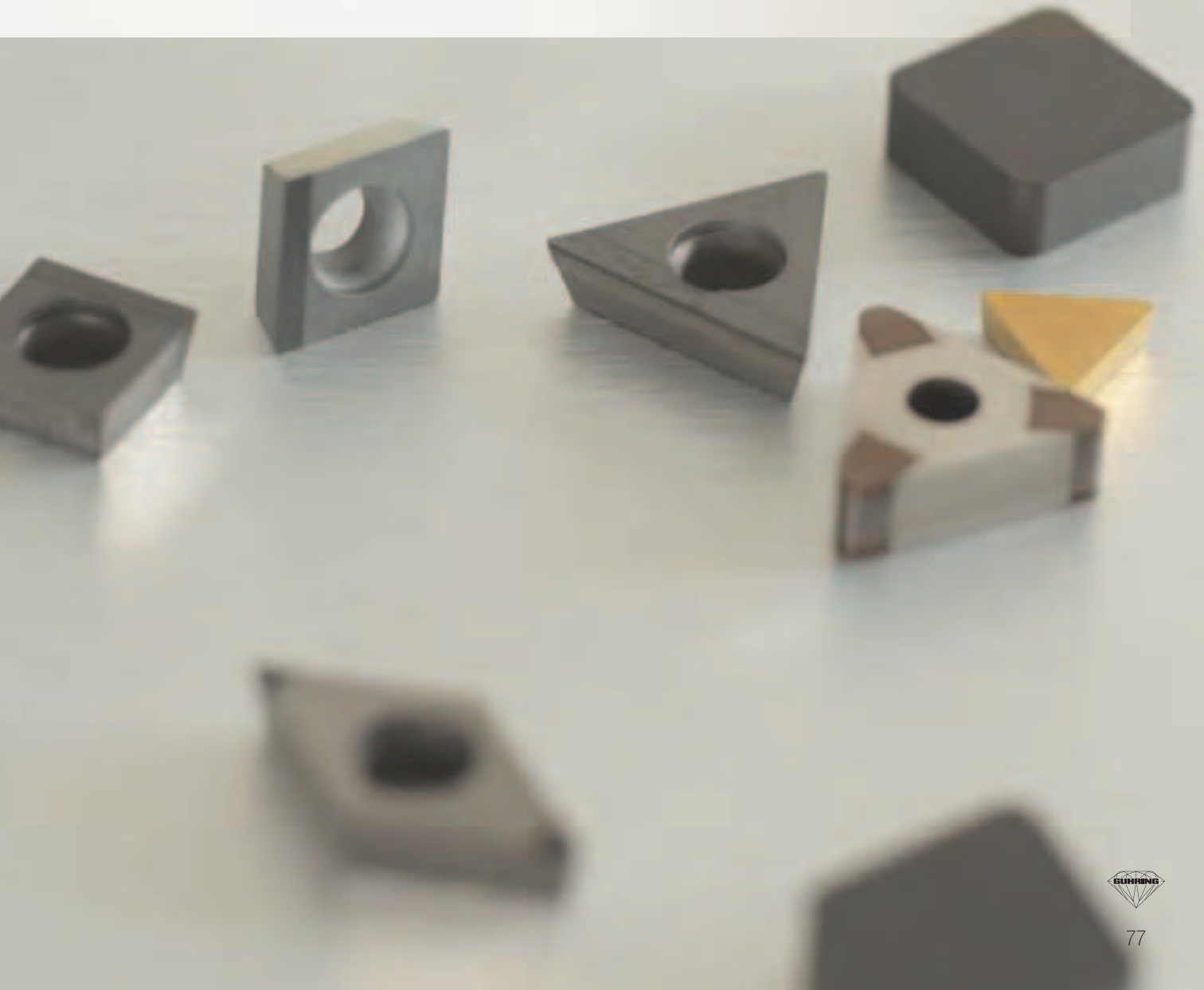

## ISO indexable inserts, PCD-tipped, form C

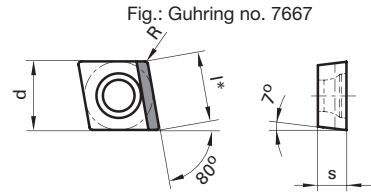
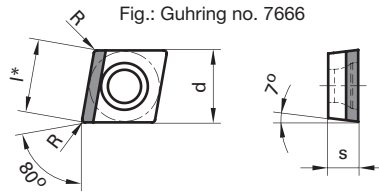
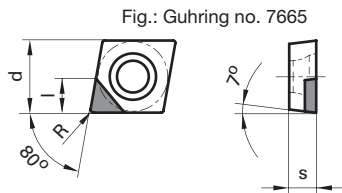

\* l: theoretical cutting point

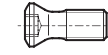
Order no. = Guhring no. + code no.	ISO code	d mm	s mm	R mm	l/l* mm		Availability
7665 62,020	CCGW 060202 FN-AS	6.350	2.380	0.20	3.00	6128 2,501	●
7665 62,040	CCGW 060204 FN-AS	6.350	2.380	0.40	3.00	6128 2,501	●
7665 93,020	CCGW 09T302 FN-AS	9.525	3.970	0.20	4.00	6128 3,500	●
7665 93,040	CCGW 09T304 FN-AS	9.525	3.970	0.40	4.00	6128 3,500	●
7666 62,020	CCGW 060202 FL-AL	6.350	2.380	0.20	6.45	6128 2,501	●
7666 62,040	CCGW 060204 FL-AL	6.350	2.380	0.40	6.45	6128 2,501	●
7666 93,020	CCGW 09T302 FL-AL	9.525	3.970	0.20	9.67	6128 3,500	●
7666 93,040	CCGW 09T304 FL-AL	9.525	3.970	0.40	9.67	6128 3,500	●
7666 124,040	CCGW 120404 FL-AL	12.700	4.760	0.40	12.90	6128 5,001	●
7666 124,080	CCGW 120408 FL-AL	12.700	4.760	0.80	12.90	6128 5,001	●
7667 62,020	CCGW 060202 FR-AL	6.350	2.380	0.20	6.45	6128 2,501	●
7667 62,040	CCGW 060204 FR-AL	6.350	2.380	0.40	6.45	6128 2,501	●
7667 93,020	CCGW 09T302 FR-AL	9.525	3.970	0.20	9.67	6128 3,500	●
7667 93,040	CCGW 09T304 FR-AL	9.525	3.970	0.40	9.67	6128 3,500	●

## ISO indexable inserts, PCD-tipped, form C, finishing geometry

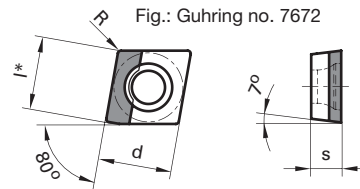
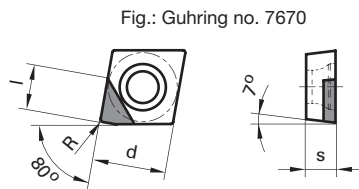

\* l: theoretical cutting point

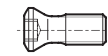
Order no. = Guhring no. + code no.	ISO code	d mm	s mm	R mm	l/l* mm		Availability
7670 62,020	CCGW 060202 FL-AS	6.350	2.380	0.20	3.75	6128 2,501	●
7670 62,040	CCGW 060204 FL-AS	6.350	2.380	0.40	3.75	6128 2,501	●
7670 93,020	CCGW 09T302 FL-AS	9.525	3.970	0.20	5.64	6128 3,500	●
7670 93,040	CCGW 09T304 FL-AS	9.525	3.970	0.40	5.64	6128 3,500	●
7672 62,020	CCGW 060202 FL-AL	6.350	2.380	0.20	6.45	6128 2,501	●
7672 62,040	CCGW 060204 FL-AL	6.350	2.380	0.40	6.45	6128 2,501	●
7672 93,020	CCGW 09T302 FL-AL	9.525	3.970	0.20	9.67	6128 3,500	●
7672 93,040	CCGW 09T304 FL-AL	9.525	3.970	0.40	9.67	6128 3,500	●

## ISO indexable inserts, PCD-tipped, form S

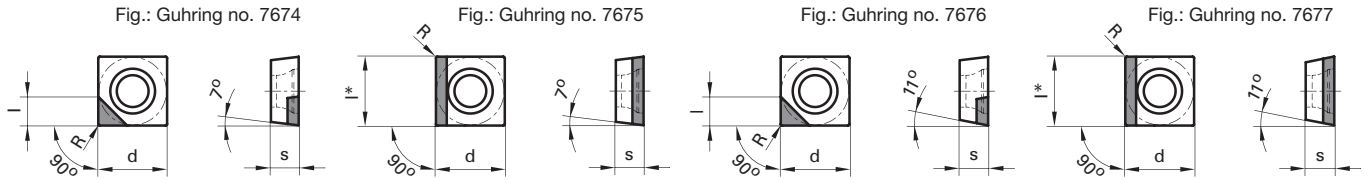

\* l: theoretical cutting point

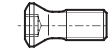
Order no. = Guhring no. + code no.	ISO code	d mm	s mm	R mm	l/* mm		Availability
7674 93,020	SCGW 09T302 FN-AS	9.525	3.970	0.20	4.00	6128 3,500	●
7676 93,020	SPGW 09T302 FN-AS	9.525	3.970	0.20	4.00	6128 3,500	●
7675 93,020	SCGW 09T302 FN-AL	9.525	3.970	0.20	9.67	6128 3,500	●
7677 93,020	SPGW 09T302 FN-AL	9.525	3.970	0.20	9.67	6128 3,500	●

## ISO indexable inserts, PCD-tipped, form T

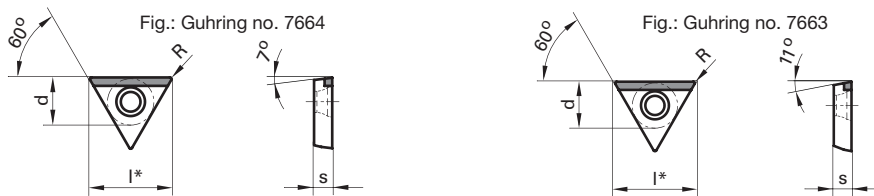

\* l: theoretical cutting point

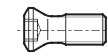
Order no. = Guhring no. + code no.	ISO code	d mm	s mm	R mm	l* mm		Availability
7664 112,020	TCGW 110202 FN-AL	6.350	2.380	0.20	11.00	6128 2,501	●
7664 163,020	TCGW 16T302 FN-AL	9.525	3.970	0.20	16.50	6128 3,500	●
7663 92,020	TPGW 090202 FN-AL	5.560	2.380	0.20	9.60	6128 2,200	●

## Cutting edge geometry

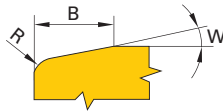

Type	Edge rounding R	Negative land width B	Negative land angle W
Type A	no	-	-
Type B	no	0,20	20°
Type C	yes	-	-
Type D	yes	0,10	10°
Type E	yes	0,10	20°
Type F	yes	0,13	15°
Type G	yes	0,15	20°
Type H	yes	0,13	25°
Type I	yes	0,20	20°

## ISO indexable inserts, CBN-tipped, form C, with screw clamping

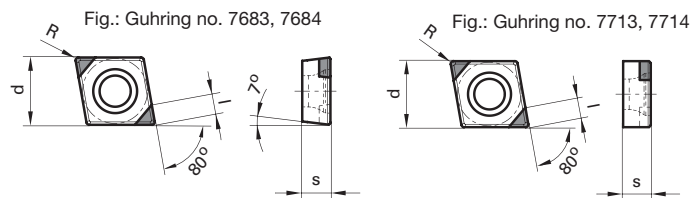

Order no. = Guhring no. + code no.	ISO code	Tool material	Cutting edge geometry	d mm	s mm	R mm	l mm		Availability
7683 62,040	CCGW 060204 TN-DS	CBN 1023	Type B	6.350	2.380	0.40	2.43	6128 2,501	●
7683 93,040	CCGW 09T304 TN-DS	CBN 1023	Type B	9.525	3.970	0.40	2.82	6128 3,500	●
7684 62,040	CCGW 060204 TN-DS	CBN 2028	Type B	6.350	2.380	0.40	2.43	6128 2,501	●
7684 93,040	CCGW 09T304 TN-DS	CBN 2028	Type B	9.525	3.970	0.40	2.82	6128 3,500	●
7713 62,040	CNGW 060204 TN-DS	CBN 1023	Type B	6.350	2.380	0.40	2.43	6128 2,501	●
7713 93,040	CNGW 09T304 TN-DS	CBN 1023	Type B	9.525	3.970	0.40	2.82	6128 3,500	●
7714 62,040	CNGW 060204 TN-DS	CBN 2028	Type B	6.350	2.380	0.40	2.43	6128 2,501	●
7714 93,040	CNGW 09T304 TN-DS	CBN 2028	Type B	9.525	3.970	0.40	2.82	6128 3,500	●

## ISO indexable inserts, CBN-tipped, form D, with screw clamping

Fig.: Guhring no. 7691, 7692

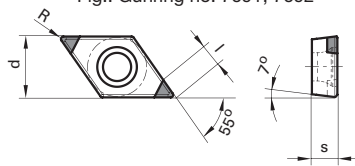

Order no. = Guhring no. + code no.	ISO code	Tool material	Cutting edge geometry	d mm	s mm	R mm	l mm		Availability
7691 72,020	DCGW 070202 TN-DS	CBN 1023	Type B	6.350	2.380	0.20	2.90	6128 2,501	●
7691 72,040	DCGW 070204 TN-DS	CBN 1023	Type B	6.350	2.380	0.40	2.90	6128 2,501	●
7691 113,040	DCGW 11T304 TN-DS	CBN 1023	Type B	9.525	3.970	0.40	3.00	6128 3,500	●
7691 113,080	DCGW 11T308 TN-DS	CBN 1023	Type B	9.525	3.970	0.80	2.50	6128 3,500	●
7692 72,020	DCGW 070202 TN-DS	CBN 2028	Type B	6.350	2.380	0.20	2.90	6128 2,501	●
7692 72,040	DCGW 070204 TN-DS	CBN 2028	Type B	6.350	2.380	0.40	2.90	6128 2,501	●
7692 113,040	DCGW 11T304 TN-DS	CBN 2028	Type B	9.525	3.970	0.40	3.00	6128 3,500	●
7692 113,080	DCGW 11T308 TN-DS	CBN 2028	Type B	9.525	3.970	0.80	2.50	6128 3,500	●

## ISO indexable inserts, CBN-tipped, form V, with screw clamping

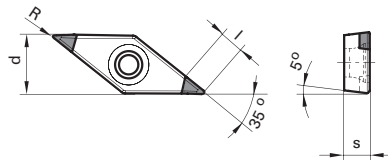

Order no. = Guhring no. + code no.	ISO code	Tool material	Cutting edge geometry	d mm	s mm	R mm	l mm		Availability
7717 164,040	VBMW 160404 TN-DSWiper	CBN 1023	Type D	9.525	4.760	0.40	4.00	6128 3,500	●
7718 164,040	VBMW 160404 TN-DSWiper	CBN 2028	Type D	9.525	4.760	0.40	4.00	6128 3,500	●
7719 164,080	VBMW 160408 TN-DS	CBN 1023	Type D	9.525	4.760	0.80	3.30	6128 3,500	●
7719 164,120	VBMW 160412 TN-DS	CBN 1023	Type D	9.525	4.760	1.20	2.40	6128 3,500	●
7720 164,080	VBMW 160408 TN-DS	CBN 1023	Type G	9.525	4.760	0.80	3.30	6128 3,500	●
7720 164,120	VBMW 160412 TN-DS	CBN 1023	Type G	9.525	4.760	1.20	2.40	6128 3,500	●
7721 164,080	VBMW 160408 TN-DS	CBN 2028	Type D	9.525	4.760	0.80	3.30	6128 3,500	●
7721 164,120	VBMW 160412 TN-DS	CBN 2028	Type D	9.525	4.760	1.20	2.40	6128 3,500	●
7722 164,080	VBMW 160408 TN-DS	CBN 2028	Type G	9.525	4.760	0.80	2.40	6128 3,500	●
7722 164,120	VBMW 160412 TN-DS	CBN 2028	Type G	9.525	4.760	1.20	2.40	6128 3,500	●

## Clamping screws for ISO indexable inserts

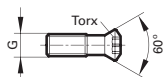

Order no. = Guhring no. + code no.	Screw	Torx	Tightening torque max. in Ncm	Availability
6128 2,200	M 2.2 x 5.0	T6	101	●
6128 2,500	M 2.5 x 5.3	T7	128	●
6128 2,501	M 2.5 x 6.5	T7	128	●
6128 2,502	M 2.5 x 5.7	T7	128	●
6128 3,500	M 3.5 x 10.0	T15	345	●
6128 3,501	M 3.5 x 12.0	T15	345	●
6128 3,502	M 3.5 x 8.5	T15	345	●
6128 3,503	M 3.5 x 8.0	T15	345	●
6128 4,000	M 4.0 x 13.5	T15	515	●
6128 4,001	M 4.0 x 8.4	T15	515	●
6128 4,002	M 4.0 x 10.8	T15	515	●
6128 4,003	M 4.0 x 0.5 x 11.0	T15	515	●
6128 4,004	M 4.0 x 9.5	T20	515	●
6128 4,005	M 4.0 x 0.5 x 9.0	T15	515	●
6128 4,500	M 4.5 x 11.0	T15	760	●
6128 4,501	M 4.5 x 7.5	T15	760	●
6128 4,502	M 4.5 x 11.0	T20	760	●
6128 5,000	M 5.0 x 17.0	T20	1020	●
6128 5,001	M 5.0 x 11.0	T20	1020	●

Tightening torque is for screws of strength grade 12.9 and results from a 90% yield point utilisation and is based on a mean friction value of 0.14μ.

## ISO indexable inserts, CBN-tipped, form C, with hole clamping, with solid carbide body

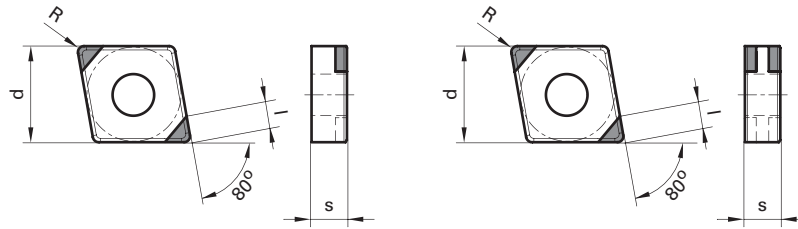

Order no. = Guhring no. + code no.	ISO code	Tool material	Cutting edge geometry	d mm	s mm	R mm	l mm	Availability
7685 124,080	CNMA 120408 TN-DS	CBN 1023	Type B	12.70	4.760	0.80	3.33	●
7685 124,120	CNMA 120412 TN-DS	CBN 1023	Type B	12.70	4.760	1.20	3.25	●
7686 124,080	CNMA 120408 TN-DS	CBN 2028	Type B	12.70	4.760	0.80	3.33	●
7686 124,120	CNMA 120412 TN-DS	CBN 2028	Type B	12.70	4.760	1.20	3.25	●
7687 124,080	CNMA 120408 TN-LS	CBN 1023	Type B	12.70	4.760	0.80	3.33	●
7687 124,120	CNMA 120412 TN-LS	CBN 1023	Type B	12.70	4.760	1.20	3.25	●
7688 124,080	CNMA 120408 TN-LS	CBN 2028	Type B	12.70	4.760	0.80	3.33	●
7688 124,120	CNMA 120412 TN-LS	CBN 2028	Type B	12.70	4.760	1.20	3.25	●

## ISO indexable inserts, CBN-tipped, form C, with hole clamping with steel body for roughing operations and interrupted cutting,

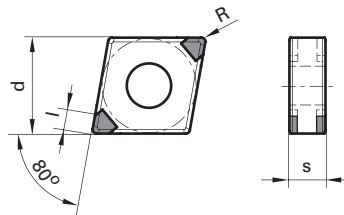

Order no. = Guhring no. + code no.	ISO code	Tool material	Cutting edge geometry	d mm	s mm	R mm	l mm	Availability
7695 124,040	CNGA120404 SN-LS	CBN 1023	Type F	12.70	4.760	0.40	2.50	●
7695 124,080	CNGA120408 SN-LS	CBN 1023	Type F	12.70	4.760	0.80	2.40	●
7695 124,120	CNGA120412 SN-LS	CBN 1023	Type F	12.70	4.760	1.20	2.30	●
7696 124,080	CNGA120408 SN-LS Wiper	CBN 1023	Type F	12.70	4.760	0.80	2.40	●
7697 124,040	CNGA120404 SN-LS	CBN 1023	Type H	12.70	4.760	0.40	2.50	●
7697 124,080	CNGA120408 SN-LS	CBN 1023	Type H	12.70	4.760	0.80	2.40	●
7697 124,120	CNGA120412 SN-LS	CBN 1023	Type H	12.70	4.760	1.20	2.30	●
7698 124,080	CNGA120408 SN-LS Wiper	CBN 1023	Type H	12.70	4.760	0.80	2.40	●

## ISO indexable inserts, CBN-tipped, form S, with hole clamping with steel body for roughing operations and interrupted cutting,

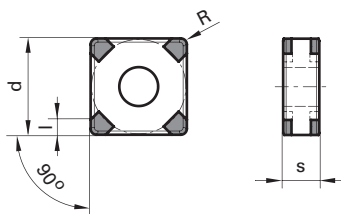

Order no. = Guhring no. + code no.	ISO code	Tool material	Cutting edge geometry	d mm	s mm	R mm	l mm	Availability
7699 124,080	SNGA120408 SN-NS	CBN 1023	Type F	12.700	4.760	0.80	2.50	●
7699 124,120	SNGA120412 SN-NS	CBN 1023	Type F	12.700	4.760	1.20	2.30	●
7700 124,080	SNGA120408 SN-NS	CBN 1023	Type H	12.700	4.760	0.80	2.50	●
7700 124,120	SNGA120412 SN-NS	CBN 1023	Type H	12.700	4.760	1.20	2.30	●

## ISO indexable inserts, CBN-tipped, form T, with hole clamping with steel body for roughing operations and interrupted cutting

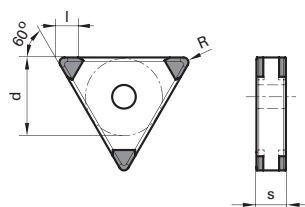

Order no. = Guhring no. + code no.	ISO code	Tool material	Cutting edge geometry	d mm	s mm	R mm	l mm	Availability
7693 164,040	TNGA160404 SN-MS	CBN 1023	Type F	9.525	4.760	0.40	3.10	●
7693 164,080	TNGA160408 SN-MS	CBN 1023	Type F	9.525	4.760	0.80	2.70	●
7693 164,012	TNGA160412 SN-MS	CBN 1023	Type F	9.525	4.760	1.20	2.30	●
7694 164,040	TNGA160404 SN-MS	CBN 1023	Type H	9.525	4.760	0.40	3.10	●
7694 164,080	TNGA160408 SN-MS	CBN 1023	Type H	9.525	4.760	0.80	2.70	●
7694 164,120	TNGA160412 SN-MS	CBN 1023	Type H	9.525	4.760	1.20	2.30	●



## ISO indexable inserts, CBN-tipped, form D, with hole clamping with steel body for roughing operations and interrupted cutting

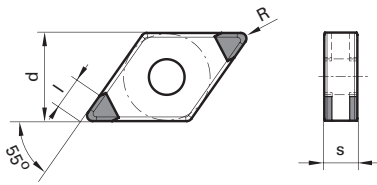

Order no. = Guhring no. + code no.	ISO code	Tool material	Cutting edge geometry	d mm	s mm	R mm	l mm	Availability
7701 154,040	DNGA150404 SN-LS	CBN 1023	Type F	12.70	4.760	0.40	3.40	●
7701 154,080	DNGA150408 SN-LS	CBN 1023	Type F	12.70	4.760	0.80	3.00	●
7701 154,120	DNGA150412 SN-LS	CBN 1023	Type F	12.70	4.760	1.20	2.50	●
7702 154,040	DNGA150404 SN-LS	CBN 1023	Type H	12.70	4.760	0.40	3.40	●
7702 154,080	DNGA150408 SN-LS	CBN 1023	Type H	12.70	4.760	0.80	3.00	●
7702 154,120	DNGA150412 SN-LS	CBN 1023	Type H	12.70	4.760	1.20	2.50	●



## ISO indexable inserts, solid CBN, form C

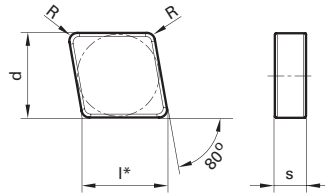

\* l: theoretical cutting point

Order no. = Guhring no. + code no.	ISO code	Tool material	Cutting edge geometry	d mm	s mm	R mm	l* mm	Availability
7689 94,080	CNGN 090408 TN-S	CBN 3018	Type B	9.525	4.760	0.80	9.67	●
7689 94,120	CNGN 090412 TN-S	CBN 3018	Type B	9.525	4.760	1.20	9.67	●
7689 124,120	CNGN 120412 TN-S	CBN 3018	Type B	12.70	4.760	1.20	12.90	●
7689 124,160	CNGN 120416 TN-S	CBN 3018	Type B	12.70	4.760	1.60	12.90	●

## ISO indexable inserts, solid CBN, form S

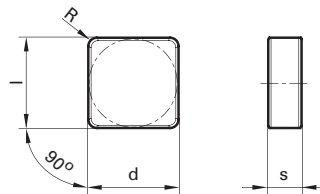

Order no. = Guhring no. + code no.	ISO code	Tool material	Cutting edge geometry	d mm	s mm	R mm	l mm	Availability
7690 94,080	SNGN 090408 TN-S	CBN 3018	Type B	9.525	4.760	0.80	9.525	●
7690 94,120	SNGN 090412 TN-S	CBN 3018	Type B	9.525	4.760	1.20	9.525	●
7690 124,120	SNGN 120412 TN-S	CBN 3018	Type B	12.70	4.760	1.20	12.70	●
7690 124,160	SNGN 120416 TN-S	CBN 3018	Type B	12.70	4.760	1.60	12.70	●

## ISO indexable inserts, solid CBN, form R

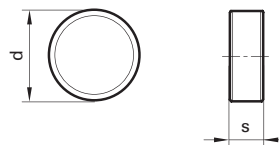

Order no. = Guhring no. + code no.	ISO code	Tool material	Cutting edge geometry	d mm	s mm	R mm	l mm	Availability
7715 124,000	RNGN 120400 TN-S	CBN 3018	Type B	12.70	4.760	-	-	●

## ISO full-face inserts, CBN, form T, for machining valve seats, for GP 100 system

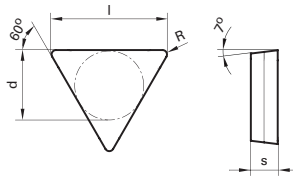

Order no. = Guhring no. + code no.	ISO code	Tool material	Surface	Cutting edge geometry	d mm	s mm	R mm	l mm	Availability
7703 61,020	TCCN 060102 FN-F	CBN 1023	○ bright	Type A	3.968	1.590	0.20	6.876	●
7703 61,040	TCCN 060104 FN-F	CBN 1023	○ bright	Type A	3.968	1.590	0.40	6.876	●
7704 61,020	TCCN 060102 FN-F	CBN 2028	○ bright	Type A	3.968	1.590	0.20	6.876	●
7704 61,040	TCCN 060104 FN-F	CBN 2028	○ bright	Type A	3.968	1.590	0.40	6.876	●
7678 61,020	TCCN 060102 EN-F	CBN 1023	Ⓢ TiN	Type C	3.968	1.590	0.20	6.876	●
7678 61,040	TCCN 060104 EN-F	CBN 1023	Ⓢ TiN	Type C	3.968	1.590	0.40	6.876	●
7705 92,040	TCCN 090204 EN-F	CBN 1024	Ⓢ TiN	Type C	5.556	2.380	0.40	9.525	●
7706 92,040	TCCN 090204 EN-F	CBN 2026	Ⓢ TiN	Type C	5.556	2.380	0.40	9.525	●
7679 61,020	TCCN 060102 EN-F	CBN 2028	Ⓢ TiN	Type C	3.968	1.590	0.20	6.876	●
7679 61,040	TCCN 060104 EN-F	CBN 2028	Ⓢ TiN	Type C	3.968	1.590	0.40	6.876	●
7679 92,040	TCCN 090204 EN-F	CBN 2028	Ⓢ TiN	Type C	5.556	2.380	0.40	9.525	●
7707 61,020	TCCN 060102 SN-F	CBN 1023	Ⓢ TiN	Type E	3.968	1.590	0.20	6.876	●
7707 61,040	TCCN 060104 SN-F	CBN 1023	Ⓢ TiN	Type E	3.968	1.590	0.40	6.876	●
7708 61,020	TCCN 060102 SN-F	CBN 2028	Ⓢ TiN	Type E	3.968	1.590	0.20	6.876	●
7708 61,040	TCCN 060104 SN-F	CBN 2028	Ⓢ TiN	Type E	3.968	1.590	0.40	6.876	●
7680 61,020	TCCN 060102 SN-F	CBN 1023	Ⓢ TiN	Type I	3.968	1.590	0.20	6.876	●
7680 61,040	TCCN 060104 SN-F	CBN 1023	Ⓢ TiN	Type I	3.968	1.590	0.40	6.876	●
7709 92,040	TCCN 090204 SN-F	CBN 1024	Ⓢ TiN	Type I	5.556	2.380	0.40	9.525	●
7710 92,040	TCCN 090204 SN-F	CBN 2026	Ⓢ TiN	Type I	5.556	2.380	0.40	9.525	●
7681 61,020	TCCN 060102 SN-F	CBN 2028	Ⓢ TiN	Type I	3.968	1.590	0.20	6.876	●
7681 61,040	TCCN 060104 SN-F	CBN 2028	Ⓢ TiN	Type I	3.968	1.590	0.40	6.876	●
7681 92,040	TCCN 090204 SN-F	CBN 2028	Ⓢ TiN	Type I	5.556	2.380	0.40	9.525	●

## ISO full-face inserts, PCD, form T, for machining valve seats, for GP 100 system

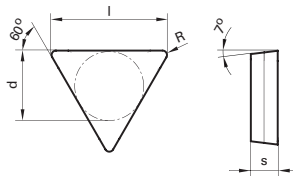

Order no. = Guhring no. + code no.	ISO-Code	Tool material	Surface	Cutting edge geometry	d mm	s mm	R mm	l mm	Availability
7712 61,020	TCCN 060102 FN-F	PCD	○ bright	Type A	3.968	1.590	0.20	6.876	●
7712 61,040	TCCN 060104 FN-F	PCD	○ bright	Type A	3.968	1.590	0.20	6.876	●

## Solid carbide ISO inserts, form T, for machining valve seats, for GP 100 system

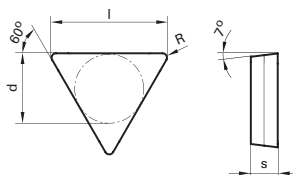

Order no. = Guhring no. + code no.	ISO-Code	Tool material	Surface	Cutting edge geometry	d mm	s mm	R mm	l mm	Availability
7711 61,020	TCCN 060102 FN-S	Solid carbide	○ bright	Type A	3.968	1.590	0.20	6.876	●
7711 61,040	TCCN 060104 FN-S	Solid carbide	○ bright	Type A	3.968	1.590	0.20	6.876	●

# ISO inserts for machining valve seat

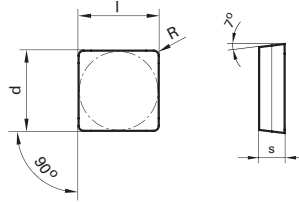

## ISO full-face inserts, CBN, form S, for GP 100 system

Order no. = Guhring no. + code no.		ISO code	Tool material	Surface	Cutting edge geometry	d mm	s mm	R mm	l mm	Availability
7716	61,020	SCGN 060102 SN-F	CBN 2028	○ bright	Type I	6.35	1.590	0.20	6.35	●

Solid carbide reamer, 6-fluted, interchangeable



Solid carbide reamer, 6-fluted, interchangeable



PCD solid head reamer, 6-fluted, interchangeable

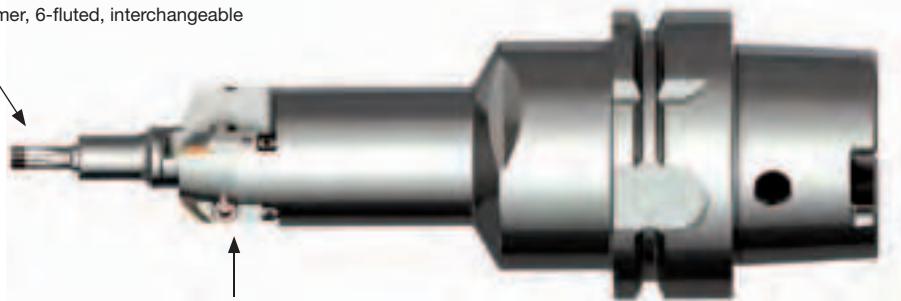

System GP 100 for machining valve seats, adjustable

PCD solid head reamer, 6-fluted, interchangeable

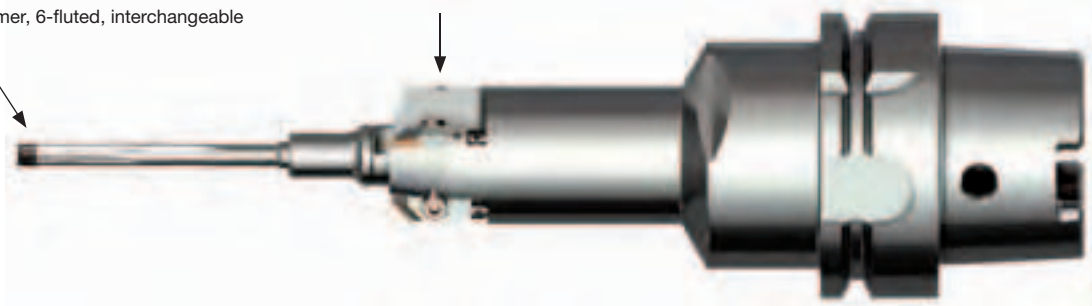

Example: Valve seat and valve guide finishing tools

# Short clamping holders KV400

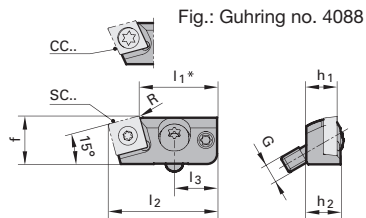
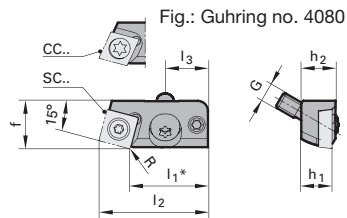

**15°** \* l: theoretical cutting point

Order no. = Guhring no. + code no.	Size	f mm	for indexable insert	l1* mm	l2 mm	l3 mm	G mm	h1 mm	h2 mm	R	Dmin	Availability
4080 6,000 06	9.5	CC..0602..	18.0	24.04	9.85	M3.5	6.3	7.3	0.2	31.0	●	
4080 9,000 09	14.0	SC..09T3..	23.0	31.83	12.5	M5	9.0	10.0	0.4	41.0	●	
4080 12,000 12	19.0	SC..1204..	30.0	41.89	16.1	M6	10.5	11.5	0.4	49.0	●	
4088 6,000 06	9.5	CC..0602..	18.0	24.04	9.85	M3.5	6.3	7.3	0.2	31.0	●	
4088 9,000 09	14.0	SC..09T3..	23.0	31.83	12.5	M5	9.0	10.0	0.4	41.0	●	
4088 12,000 12	19.0	SC..1204..	30.0	41.89	16.1	M6	10.5	11.5	0.4	49.0	●	

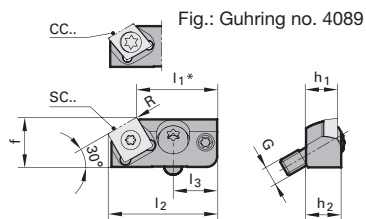
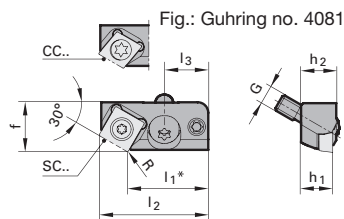

**30°** \* l: theoretical cutting point

Order no. = Guhring no. + code no.	Size	f mm	for indexable insert	l1* mm	l2 mm	l3 mm	G mm	h1 mm	h2 mm	R	Dmin	Availability
4081 6,000 06	9.5	CC..0602..	18.0	23.43	9.85	M3.5	6.3	7.3	0.2	26.0	●	
4081 9,000 09	14.0	SC..09T3..	23.0	30.96	12.5	M5	9.0	10.0	0.4	36.0	●	
4081 12,000 12	19.0	SC..1204..	30.0	40.71	16.1	M6	10.5	11.5	0.4	42.0	●	
4089 6,000 06	9.5	CC..0602..	18.0	23.43	9.85	M3.5	6.3	7.3	0.2	26.0	●	
4089 9,000 09	14.0	SC..09T3..	23.0	30.96	12.5	M5	9.0	10.0	0.4	36.0	●	
4089 12,000 12	19.0	SC..1204..	30.0	40.71	16.1	M6	10.5	11.5	0.4	42.0	●	

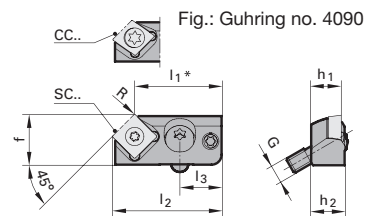
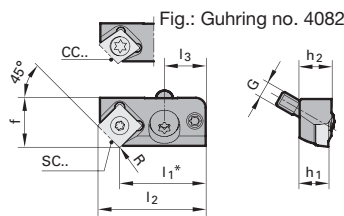

**45°** \* l: theoretical cutting point

Order no. = Guhring no. + code no.	Size	f mm	for indexable insert	l1* mm	l2 mm	l3 mm	G mm	h1 mm	h2 mm	R	Dmin	Availability
4082 6,000 06	9.5	CC..0602..	19.5	23.97	9.85	M3.5	6.3	7.3	0.2	26.0	●	
4082 9,000 09	15.0	SC..09T3..	26.0	32.57	12.5	M5	9.0	10.0	0.4	36.0	●	
4082 12,000 12	20.0	SC..1204..	34.0	42.81	16.1	M6	10.5	11.5	0.4	42.0	●	
4090 6,000 06	9.5	CC..0602..	19.5	23.97	9.85	M3.5	6.3	7.3	0.2	26.0	●	
4090 9,000 09	15.0	SC..09T3..	26.0	32.57	12.5	M5	9.0	10.0	0.4	36.0	●	
4090 12,000 12	20.0	SC..1204..	34.0	42.81	16.1	M6	10.5	11.5	0.4	42.0	●	

# Short clamping holders KV400

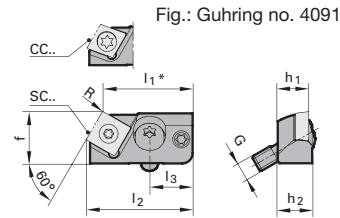
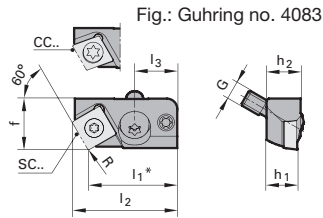

60° \* I: theoretical cutting point

Order no. = Guhring no. + code no.	Size	f mm	for indexable insert	l1* mm	l2 mm	l3 mm	G mm	h1 mm	h2 mm	R	Dmin	Availability
4083 6,000	06	9.5	CC..0602..	19.5	22.72	9.85	M3.5	6.3	7.3	0.2	26.0	●
4083 9,000	09	15.0	SC..09T3..	26.0	30.76	12.5	M5	9.0	10.0	0.4	36.0	●
4083 12,000	12	20.0	SC..1204..	34.0	40.35	16.1	M6	10.5	11.5	0.4	42.0	●
4091 6,000	06	9.5	CC..0602..	19.5	22.72	9.85	M3.5	6.3	7.3	0.2	26.0	●
4091 9,000	09	15.0	SC..09T3..	26.0	30.76	12.5	M5	9.0	10.0	0.4	36.0	●
4091 12,000	12	20.0	SC..1204..	34.0	40.35	16.1	M6	10.5	11.5	0.4	42.0	●

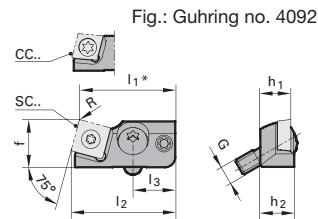
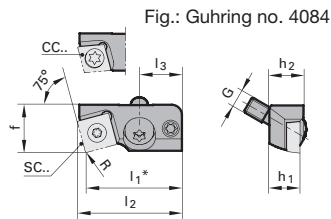

75° \* I: theoretical cutting point

Order no. = Guhring no. + code no.	Size	f mm	for indexable insert	l1* mm	l2 mm	l3 mm	G mm	h1 mm	h2 mm	R	Dmin	Availability
4084 6,000	06	9.5	CC..0602.. R/N	20.0	21.76	9.85	M3.5	6.3	7.3	0.2	31.0	●
4084 9,000	09	14.0	SC..09T3.. L/N	28.0	30.66	12.5	M5	9.0	10.0	0.4	41.0	●
4084 12,000	12	19.0	SC..1204.. L/N	36.0	39.48	16.1	M6	10.5	11.5	0.4	49.0	●
4092 6,000	06	9.5	CC..0602.. L/N	20.0	21.76	9.85	M3.5	6.3	7.3	0.2	31.0	●
4092 9,000	09	14.0	SC..09T3.. R/N	28.0	30.66	12.5	M5	9.0	10.0	0.4	41.0	●
4092 12,000	12	19.0	SC..1204.. R/N	36.0	39.48	16.1	M6	10.5	11.5	0.4	49.0	●

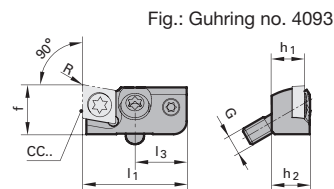
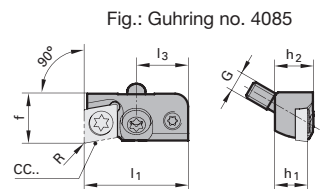

90°

Order no. = Guhring no. + code no.	Size	f mm	for indexable insert	l1 mm	l2 mm	l3 mm	G mm	h1 mm	h2 mm	R	Dmin	Availability
4085 6,000	06	9.5	CC..0602.. L/N	20.0	-	9.85	M3.5	6.3	7.3	0.2	26.0	●
4085 9,000	09	14.0	CC..09T3.. L/N	28.0	-	12.5	M5	9.0	10.0	0.4	36.0	●
4085 12,000	12	19.0	CC..1204.. L/N	36.0	-	16.1	M6	10.5	11.5	0.4	42.0	●
4093 6,000	06	9.5	CC..0602.. R/N	20.0	-	9.85	M3.5	6.3	7.3	0.2	26.0	●
4093 9,000	09	14.0	CC..09T3.. R/N	28.0	-	12.5	M5	9.0	10.0	0.4	36.0	●
4093 12,000	12	19.0	CC..1204.. R/N	36.0	-	16.1	M6	10.5	11.5	0.4	42.0	●

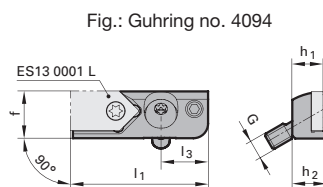
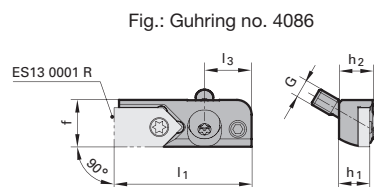

for special insert blanks

Order no. = Guhring no. + code no.	Size	f mm	for indexable insert	l1 mm	l2 mm	l3 mm	G mm	h1 mm	h2 mm	R	Dmin	Availability
4086 13,000	13	16.0	ES13 0001 R	47.0	-	16.1	M6	10.5	11.5	-	42.0	●
4094 13,000	13	16.0	ES13 0001 L	47.0	-	16.1	M6	10.5	11.5	-	42.0	●

## Clamping screws for short clamping holders KV 400

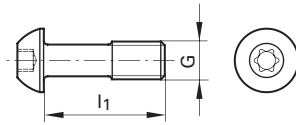

Order no. = Guhring no. + code no.	Size	G	l <sub>1</sub> mm	Torx	Tightening torque max. in Ncm	Availability
4059 3,501	06	M3.5	10.0	T 15	345	●
4059 5,001	09	M 5	14.7	T 20	900	●
4059 6,001	12	M 6	17.5	T 25	1300	●

## Threaded pins for short clamping holders KV 400

Fig.: Guhring no. 4060

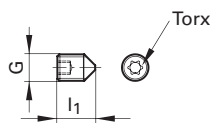
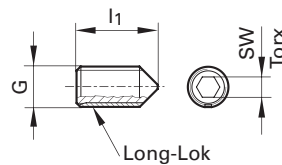
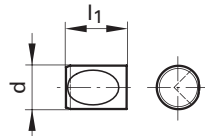

Fig.: Guhring no. 1689



Order no. = Guhring no. + code no.	Size	G	l <sub>1</sub> mm	Torx	Availability
4060 3,501	06	M3.5x0.35	5	T 7	●
1689 5,003	09	M 5	6.0	T 15	●
1689 6,001	12	M6	8.0	SW 3	●

## Adjustment screws for short clamping holders KV 400



Order no. = Guhring no. + code no.	Size	d mm	l <sub>1</sub> mm	Availability
4058 3,502	06	3.5	6.2	●
4058 5,002	09	5.0	7.0	●
4058 6,002	12	6.0	8.7	●

# Threaded key adjustment unit for direct installation of inserts

The threaded key adjustment enables the realisation of close stepped tools for finishing operations. A particular advantage is the simple adjustment possibility of the indexable inserts for the adjustment range 0.30 mm in diameter with every design. Depending on the insert position it is possible to carry out an axial as well as a radial adjustment,

herewith adjusting the overall length as well as the diameter. Per right hand turn, the fine adjustment forces the insert into the adjustment direction.

Due to the small dimensions it is possible to produce tools from diameter 16.0 mm with insert size 06 (see table). Different basic insert forms can be applied, i.e. triangular, rhombic or square.

No. of edges	from tool Ø		
	index. insert 06	index. insert 09	index. insert 12
1	Ø 16 mm	Ø 29 mm	Ø 36 mm
2	Ø 23 mm	Ø 33 mm	Ø 44 mm
3	Ø 30 mm	Ø 44 mm	Ø 60 mm

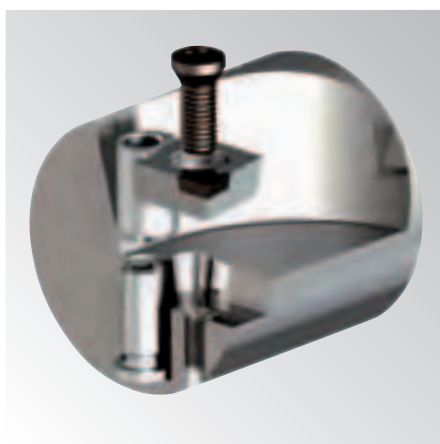

Easy:  
The installation and fine adjustment...

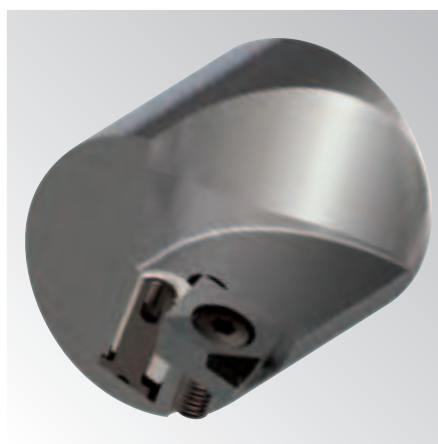

...of a single fluted tool with indexable inserts...

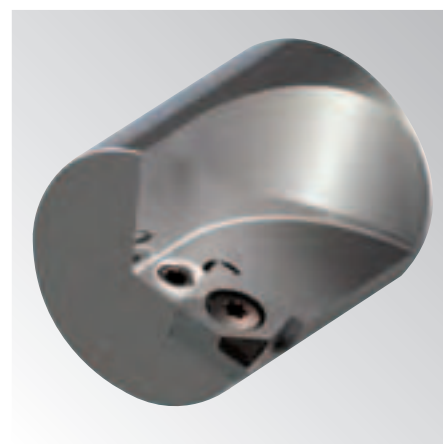

...via threaded key.

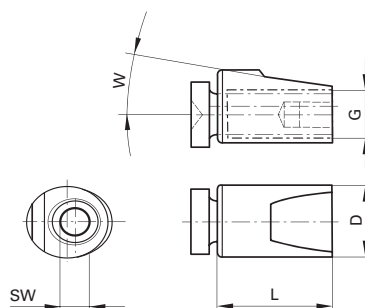

Order no. = Guhring no. + code no.	Size	for indexable inserts	D mm	G	L mm	W °	SW	Availability
4007 4,501	06	CC..06.. / SC..06..	4.5	M 3	5.5	7	1.5	●
4007 4,502	06	CP..06.. / SP..06..	4.5	M 3	5.5	11	1.5	●
4007 6,001	09	CC..09T3.. / SC..09T3.. / TC..1102..	6.0	M4x0.5	9.3	7	2.0	●
4007 6,002	09	CP..09T3.. / SP..09T3.. / TP..1102..	6.0	M4x0.5	9.3	11	2.0	●
4007 9,001	12	CC..1204.. / SC..1204.. / TC..16T3..	9.0	M6x0.5	12.7	7	3.0	●
4007 9,002	12	CP..1204.. / SP..1204.. / TP..16T3..	9.0	M6x0.5	12.7	11	3.0	●
4007 6,003	09	TC..0902..	6.0	M4x0.5	7.7	7	2.0	●
4007 6,004	09	TP..0902..	6.0	M4x0.5	5.8	11	2.0	●



# Threaded key adjustment unit for KV 400 short clamping holders

The combination of threaded key installation system, applying several adjustment and cartridge solution offers the complete fine adjustment for diameter, length and tapering. Under ideal application conditions, stepped precision holes with quality IT7 can be produced with the direct as well as the cartridge

The resulting minimum machining diameters can be taken from the following table.

Short clamping holder size	No. of edges	D min for short clamping holders Guhring no.					
		4080 4088 15°	4081 4089 30°	4082 4090 45°	4083 4091 60°	4084 4092 75°	4085 4093 90°
06	1	31	26	26	26	31	26
	2	31	29	29	29	31	29
	3	36	36	36	36	36	36
09	1	41	36	36	36	41	36
	2	41	41	42	42	41	41
	3	51	51	53	53	51	51
12	1	49	42	42	42	49	42
	2	55	55	57	57	55	55
	3	71	71	73	73	71	71



Cartridge type installation:  
The fine adjustment is located outside the cartridge with threaded key adjustment.

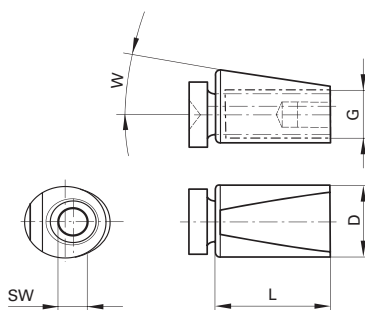

Order no. = Guhring no. + code no.	Size	for short clamping holder KV 400	D mm	G	L mm	W °	SW	Availability
4007 4,500	06	Size 06	4.5	M 3	5.5	11	1.5	●
4007 6,000	09	Size 09	6.0	M4x0.5	9.3	11	2.0	●
4007 9,000	12	Size 12	9.0	M6x0.5	12.7	11	3.0	●

# Indexable insert description to DIN ISO 1832:2005-11

Insert form			Clearance angle		Tolerance				Insert type		Insert size / I/C diameter /									
De-scription	Angle	Form	De-scription	Angle	Tolerance class in relation to inscribed circle			Limit dimensions			De-scription	Form	Size	Form	C	D	E	H	M	O
								d ± mm	m ± mm	s ± mm										
A	85°		A	3°	A	-	0.025	0.005	0.025	A		03	I/C edge l. x)				6.350 3.666		7.938 3.288	
B	82°		B	5°	C	-	0.025	0.013	0.025	B		04	I/C edge l. x)	4.760 4.833	3.970 4.853	4.760 4.928	7.938 4.583	4.760 4.772	9.525 3.945	
C	80°				D	-	0.010	0.010	0.010	C		05	I/C edge l. x)	5.560 5.646	4.760 5.811	5.560 5.756	9.525 5.499	5.560 5.574	12.700 5.261	
D	55°		C	7°	E	-	0.025	0.025	0.025	F		06	I/C edge l. x)	6.350 6.448	5.560 6.788	6.350 6.574		6.350 6.366	15.875 6.576	
E	75°				F	-	0.013	0.005	0.025	G		07	I/C edge l. x)		6.350 7.752		12.700 7.332	7.938 7.957	19.050 7.891	
H	120°				G	-	0.025	0.025	0.130	H		08	I/C edge l. x)	7.938 8.060		7.938 8.218				
K	55°		E	20°	H	-	0.013	0.013	0.025	J		M	I/C edge l. x)							25.400 10.521
L	90°				J	4.76 - 9.25 12.7 15.875 - 19.05 25.4	0.050 0.080 0.100 0.130	0.005	0.025	K										
M	86°		G	30°	K	4.76 - 9.25 12.7 15.875 - 19.05 25.4	0.050 0.080 0.100 0.130	0.013	0.025	L		R	I/C edge l. x)	12.700 12.896						31.75 13.151
O	135°				L	4.76 - 9.25 12.7 15.875 - 19.05 25.4	0.050 0.080 0.100 0.130	0.025	0.025	M										
P	108°		N	0°	M (not form D+V see exceptions)	4.76 - 9.25 12.7 15.875 - 19.05 25.4	0.050 0.080 0.100 0.130	0.080 0.130 0.150 0.180	0.130	N		T	I/C edge l. x)	12.700 15.504					15.875 15.914	
R					N	4.76 - 9.25 12.7 15.875 - 19.05 25.4	0.050 0.080 0.100 0.130	0.080 0.130 0.150 0.180	0.025	U										15
S	90°		P	11°	N (not form D+V see exceptions)	4.76 - 9.25 12.7 15.875 - 19.05 25.4	0.050 0.080 0.100 0.130	0.080 0.130 0.150 0.180	0.025	U		W	I/C edge l. x)							
T	60°				U	4.76 - 9.25 12.7 15.875 - 19.05 25.4	0.080 0.130 0.180 0.250	0.130 0.200 0.270 0.380	0.130	X										
V	35°		O	others	U	4.76 - 9.25 12.7 15.875 - 19.05 25.4	0.080 0.130 0.180 0.250	0.130 0.200 0.270 0.380	0.130	W		X	Special design	I/C edge l. x)	19.050 19.826	15.875 19.380	19.050 19.722		19.050 19.097	
W	80°				X															
<b>C</b>			<b>C</b>		<b>G</b>				<b>W</b>		<b>09</b>									

### Exceptions

M+N form D 	4.76 - 9.25 12.7 15.875 - 19.05 25.4	0.050 0.080 0.100 -	0.110	as above
M+N form V 	6.35 7.94 9.53	0.050	0.160	as above

x) mathematical, theoretical value for a corner radius of 0.00 mm see also DIN 4988

Hole diameter/countersink diameter			
Diameter	Indexable insert with countersink (40° - 60°) to DIN/ISO 6987 insert type Q, T, W		Indexable insert with cylindrical hole to DIN 4988 insert type A, G, M
	d1	d2	d1
4.760	2.150	2.700	-
5.560	2.500	3.300	-
6.000	2.800	3.750	-
6.350	2.800	3.750	2.260
7.940	3.400	4.500	-
8.000	3.400	4.500	-
9.525	4.400	6.000	3.810
10.000	4.400	6.000	-
12.000	4.400	6.000	-
12.700	5.500	7.500	5.160
15.875	5.500	7.500	6.350
16.000	5.500	7.500	-
19.050	6.500	9.000	7.940
20.000	6.500	9.000	-
25.000	8.600	12.000	-
25.400	8.600	12.000	9.120

edge length					
P	R	S	T	V	W
					5.560 2.716
6.350 4.614		4.760 4.760			6.350 4.344
7.938 5.765		5.560 5.560			7.938 5.430
9.525 6.920	6.350 6.00*)	6.350 6.350	3.970 6.876	3.970 6.921	9.525 6.515
	7.938	7.938 7.938			
	8.00*)		4.760 8.245	4.760 8.299	12.700 8.687
12.700 9.227	9.525	9.525 9.525	5.560 9.630	5.560 9.694	
	10.00*)				15.875 10.859
15.875 11.534			6.350 10.999	6.350 11.071	
	12.700 12.00*)	12.700 12.700			
19.050 13.841			7.938 13.749	7.938 13.839	19.050 13.031
	15.875	15.875 15.875			
	16.00*)		9.525 16.498	9.525 16.606	
					25.400 17.375
	19.050	19.050 19.050			

Insert thickness	
Description	s mm
01	1.59
T1	1.98
02	2.38
03	3.18
T3	3.97
04	4.76
05	5.56
06	6.35
07	7.94
09	9.52
12	12.7
<b>T3</b>	

Cutting edge corner	
Description	Radius mm
00	sharp point / indication for round insert inch
M0	Indication for round insert metric
02	0.2
04	0.4
08	0.8
12	1.2
16	1.6
20	2.0
<b>04</b>	

Cutting edge corner design	
Description	Form
F	sharp
E	rounded
T	chamfered
S	chamfered + rounded
K	double chamfered
P	double chamfered + rounded
<b>F</b>	

Cutting direction	
Description	Form
R	right-hand
L	left-hand
N	neutral
<b>R</b>	

Fitting form	
Corner fitting (choice) S = short cutting edge	
AS	1 corner on one side e.g. C insert (1 cutting edge)
DS	2 corners on one side e.g. V insert (2 cutting edges)
CS	3 corners on one side e.g. T insert (3 cutting edges)
DS	4 corners on one side e.g. S insert (4 cutting edges)
KS	1 corner on two sides e.g. C insert (2 cutting edges)
LS	2 corners on two sides e.g. D insert (4 cutting edges)
MS	3 corners on two sides e.g. T insert (6 cutting edges)
NS	4 corners on two sides e.g. S insert (8 cutting edges)
Shank fitting (choice) L = long cutting edge	
AL	One cutting edge along the entire length
Entire surface	
S	Solid
F	Full-face
<b>AS</b>	

\*) = Size to ISO 1832:2005-11 table A.2.  
Round cutting inserts "metric" design.  
Distinction see column cutting edge corner  
(M0 = metric, 00 = inch)

Planar chamfer	
Setting angle Kr of main cutting edge in feed direction	Clearance angle of planar chamfer
A 45°	A 3°
D 60°	B 5°
E 75°	C 7°
F 85°	D 15°
P 90°	E 20°
Z *	F 25°
	G 30°
	N 0°
	P 11°
	Z *

\*Special design

Note:  
Overview is for information only.  
No liability is accepted for the correctness of the contents.  
Is not subject to modification.  
Definitive data can be found in the respective standards.

# Indexable insert description to ANSI (inch dimensions)

Insert form			Clearance angle		Tolerance				Insert type		Insert size						
Description	Angle	Form	Description	Angle	Tolerance class	Limit dim. (inch/mm)			Description	Form	Size	IC		C	D	E	H
						B±	A±	T±				inch	mm				
A	85°		A	3°	A	0.0002" 0.005	0.0010" 0.025	0.0010" 0.025	A		1.25	5/32"	3.969	4.030	4.845	4.109	2.292
B	82°		B	5°	B	0.0002" 0.005	0.0010" 0.025	0.0050" 0.125	B		1.5	3/16"	4.763	4.836	5.815	4.931	2.750
C	80°				C	0.0005" 0.013	0.0010" 0.025	0.0010" 0.025	C								
D	55°		C	7°	D	0.0005" 0.013	0.0010" 0.025	0.0050" 0.125	F		1.75	7/32"	5.556	5.642	6.783	5.752	3.208
E	75°				E	0.0010" 0.025	0.0010" 0.025	0.0010" 0.025	G								
H	120°				D	15°	F	0.0002" 0.005	0.0005" 0.013	0.0010" 0.025							
K	55°		E	20°	G	0.0010" 0.025	0.0010" 0.025	0.0050" 0.125	J		2.5	5/16"	7.938	8.060	9.691	8.218	4.583
L	90°				H	0.0005" 0.013	0.0005" 0.013	0.0010" 0.025	M								
M	86°		F	25°	J	0.0002" 0.005	*	0.0010" 0.025	N		4	1/2"	12.700	12.896	15.504	13.148	7.332
O	135°				K	0.0010" 0.025	*	0.0010" 0.025	Q								
P	108°		G	30°	L	0.0010" 0.025	*	0.0010" 0.025	R		5	5/8"	15.875	16.120	19.380	16.435	9.165
R					M	*	*	0.0050" 0.125	T								
S	90°		N	0°	N	*	*	0.0010" 0.025	U		6	3/4"	19.050	19.826	23.256	19.722	10.999
T	60°				P	11°	U	*	*	0.0050" 0.125							
V	35°		O	other	X	Special design			W		8	1"	25.400	24.878	29.909	25.364	14.145
W	80°				X	Special design			X	Special design							
<b>C</b>			<b>C</b>		<b>G</b>				<b>W</b>								

Edge length in mm

### Extended tolerance specifications \*

Insert form	Clear.-angle	Tolerance	3/16"	7/32"	1/4"	5/16"	3/8"	1/2"	5/8"	3/4"	1"	1 1/4"
C, E, H, M, O, P, S, T, R, W	A	J, K, L, M, N	0.002" 0.051	0.002" 0.051	0.002" 0.051	0.002" 0.051	0.002" 0.051	0.003" 0.076	0.004" 0.102	0.004" 0.102	0.005" 0.127	0.006" 0.152
		U	0.003" 0.076	0.003" 0.076	0.003" 0.076	0.003" 0.076	0.003" 0.076	0.005" 0.127	0.007" 0.178	0.007" 0.178	0.010" 0.254	0.010" 0.254
	B	M, N	0.003" 0.076	0.003" 0.076	0.003" 0.076	0.003" 0.076	0.003" 0.076	0.005" 0.127	0.006" 0.152	0.006" 0.152	0.007" 0.178	0.008" 0.203
		U	0.005" 0.127	0.005" 0.127	0.005" 0.127	0.005" 0.127	0.005" 0.127	0.008" 0.203	0.011" 0.279	0.011" 0.279	0.015" 0.381	0.015" 0.381
D	A	J, K, L, M, N, U	0.002" 0.051	0.002" 0.051	0.002" 0.051	0.002" 0.051	0.002" 0.051	0.003" 0.076	0.004" 0.102	0.004" 0.102	0.004" 0.102	0.004" 0.102
	B	M, N, U	0.004" 0.102	0.004" 0.102	0.004" 0.102	0.004" 0.102	0.004" 0.102	0.006" 0.152	0.007" 0.178	0.007" 0.178	0.007" 0.178	0.007" 0.178

/ I/C diameter / edge length							
M	O	P	R	S	T	V	W
3.979	1.644	2.884	3.969	3.969	6.875	6.920	2.715
4.775	1.973	3.461	4.763	4.763	8.250	8.304	3.258
5.570	2.301	4.037	5.556	5.556	9.623	9.687	3.801
6.366	2.630	4.614	6.350	6.350	10.999	11.071	4.344
7.957	3.288	5.765	7.938	7.938	13.749	13.839	5.430
9.548	3.945	6.920	9.53	9.53	16.498	16.606	6.515
12.731	5.261	9.227	12.700	12.700	21.997	22.142	8.687
15.914	6.576	11.534	15.875	15.875	27.496	27.677	10.859
19.097	7.891	13.841	19.050	19.050	32.996	33.296	13.031
24.560	10.148	17.800	25.400	25.400	42.435	42.714	17.375
31.828	13.151	23.068	31.750	31.750	54.993	55.354	21.718
<b>4</b>							

Insert thickness		
Description	s inch	s mm
1	1/16"	1.59
1.2	5/64"	1.98
1.5	3/32"	2.38
2	1/8"	3.175
2.5	5/32"	3.97
3	3/16"	4.763
3.5	7/32"	5.56
4	1/4"	6.35
5	5/16"	7.938
6	3/8"	9.53
<b>3</b>		

Cutting edge corner		
Description	Radius inch	Radius mm
0	0"	0
0.2	0.004"	0.102
0.5	0.008"	0.203
1	1/64"	0.397
2	1/32"	0.798
3	3/64"	1.191
4	1/16"	1.588
5	5/64"	1.984
6	3/32"	2.381
7	7/64"	2.778
8	1/8"	3.175
<b>1</b>		

Cutting direction	
Description	Form
R	
L	
N	
<b>R</b>	

Cutt. edge corner design	
Description	Form
F	
E	
T	
S	
K	
P	
<b>F</b>	

Comparison insert thickness		
Descr. ANSI	Descr. ISO	s mm
1	01	1.59
1.2	T1	1.98
1.5	02	2.38
2	03	3.18
2.5	T3	3.97
3	04	4.76
3.5	06	5.56
4	05	6.35
5	07	7.94

Comparison ANSI ISO - Radius		
Descr. ANSI	Descr. ISO	Radius mm
0	00	0
0.5	02	0.2
1	04	0.4
2	08	0.8
3	12	1.2
4	16	1.6
5	20	2.0
6	24	2.4
7	28	2.8

# Tool materials PCD and CBN

It is not only the extreme hardness of superhard tool materials but also their high heat-resistance which enables highest cutting rates and increased productivity. One disadvantage is however their low toughness.

Economical application is only possible on extremely rigid machines and for a specific range of application.

Guhring description	Classification	Range of application, characteristics	Average grain size	Diamond content
<b>PCD</b>	Fine grain	Aluminium and AlSi-alloys <10%Si, magnesium alloys, brass, copper, bronze, wood composite materials, excellent cutting edge quality, high abrasion resistance, excellent surface qualities	2-4 µm	appr. 90 %
	Medium grain	Guhring standard grade AlSi-alloys <14%Si, copper alloys, graphite and graphite composite materials, wood composite materials, unsintered ceramic and carbide (<15% binding metal content) excellent abrasion resistance, good surface qualities	5-10 µm	appr. 92 %
	Coarse grain	Roughing and finishing applications AlSi-alloys >14%Si and other abrasive machining applications, MMC, sintered ceramic and carbide (<15% binding metal content), extreme abrasion resistance, high shock resistance, long tool life with acceptable to good surface quality	25 µm	appr. 94 %
	Mixed grain	Abrasive machining applications (i.e.: >14% AlSi-alloys, MMC, composite materials) highest wear resistance, excellent shock resistance, extreme abrasion resistance with good edge roughness, long tool life with very good surface quality	2-4 µm+ 25 µm	appr. 95 %
<b>CBN 10..</b>	Low CBN-content	CBN tool material with carbide base for finishing machining of, for example, case hardened steels, heat-treatable steels, tool steels, grey cast iron, suitable for continuous and interrupted cut applications (especially hard turning) with a chip removal <0.5mm, high pressure resistance, low thermal conductivity, excellent abrasion resistance, chemical stability, good shock toughness for high removal rates, excellent surface finish and long tool life	2 µm	50-65 % CBN-content
<b>CBN 20..</b>	High CBN-content with carbide base	CBN tool material with carbide base for the machining of, for example, pearlitic grey cast iron (> 45 HRC), hardened steel, tool and structural profile steels, powder metallurgic Fe-sinter materials, alloys on Ni/Cr basis (nickel base alloys - "Super-alloys") thermal sprayed alloy & hard coatings on Co-, Ni- und Fe-basis, suitable for continuous and interrupted cut applications with a medium chip removal (typical 0.5 - 1.5mm) high thermal conductivity, high break toughness, high surface qualities	2 µm	80-95 % CBN-content
<b>CBN 30..</b>	High CBN-content without carbide base	Solid CBN tool material without carbide base for rough machining of pearlitic grey cast iron, chilled cast iron (> 45 HRC), hardened steels with high break toughness, excellent wear resistance, very good chemical hardness, high specific removal rate For application in tool holders, drilling and boring tools, recessing tools as well as cutter heads with clamping element and negative rake angle geometry	15 µm	80-95 % CBN-content

## Carbide application

Cutting material grade	Carbide grade	Coating	Colour	Coating structure	Coating hardness	Application range
K10	K10	uncoated	-	-	-	aluminium and cast materials
K10-S	K10	TiN	golden yellow	single-layer	2300 HV	universal
K10-O	K10	AlTiN	blue anthracite	single-layer	3400 HV	HSC machining
K10-Proton	K10	TiAlN	blue violet	multi-layer	3400 HV	cast materials
K20-A	K20	TiAlN	grey	single-layer	3200 HV	universal
P10	P10	uncoated	-	-	-	unalloyed steels
P40	P40	uncoated	-	-	-	unalloyed steels
P40-S	P40	TiN	golden yellow	single-layer	2300 HV	steel materials
P40-O	P40	AlTiN	blue anthracite	single-layer	3400 HV	steel materials
P40-Proton	P40	TiAlN	blue violet	multi-layer	3400 HV	steel and cast materials

## Guide values for surface finish

In order to select the right feedrate per tooth (fz) please pay also attention to the table below „Guide values for surface finish“.

Wiper geometries lead in many cases to better surface finish and higher feed rates along with a constant high accuracy.

**Guide values for surface finish relative to feedrate and corner radius**

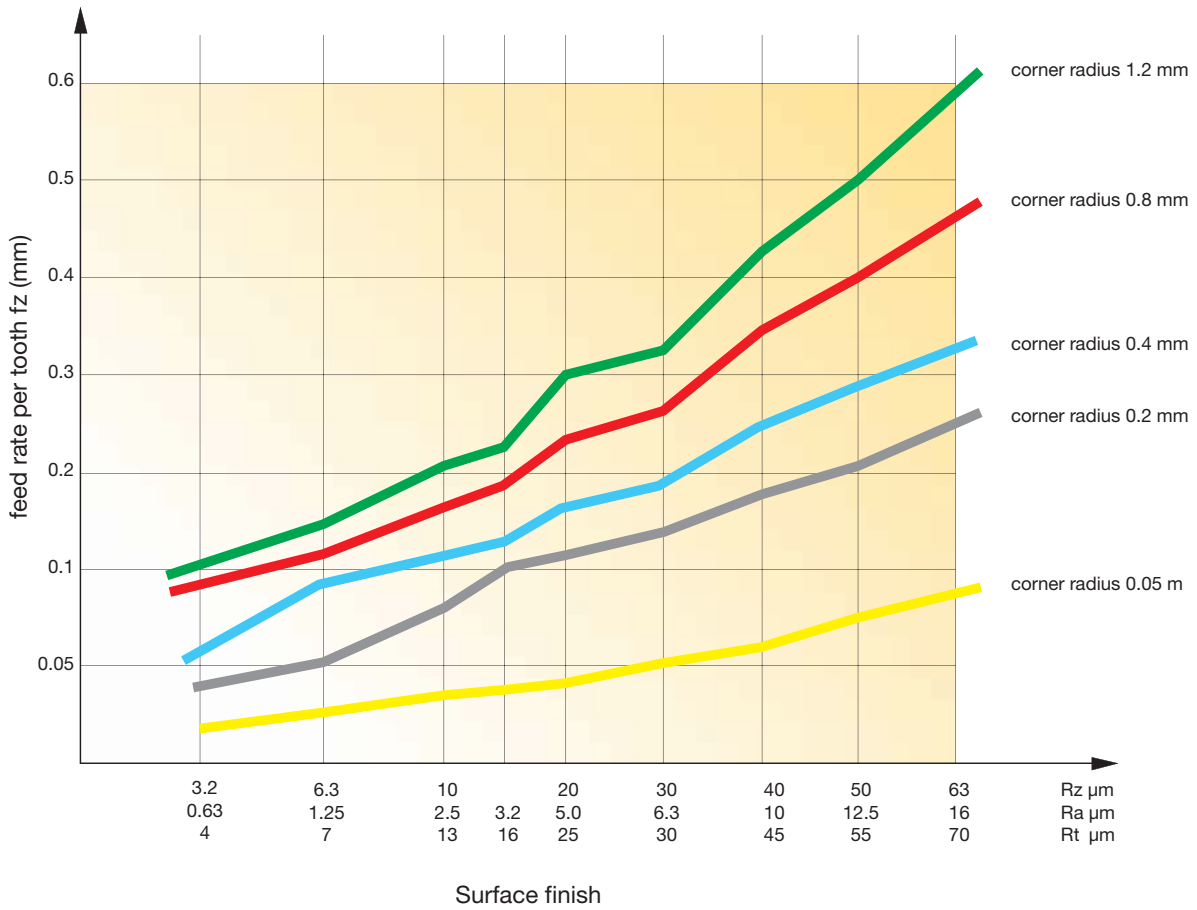

# Cutting recommendations for inserts

Cutting groups	Material groups	Composition / Structure	Tensile strength RM (MPa)	Hardness HB HRC	K10 bright	K10 <b>S</b>	K10 <b>A</b>	K10 Proton	K20 <b>A</b>
1.1	unalloyed steel Cast steel Machining steel	C=0,1 -0,25 annealed, long chip.	420	125					120 - 180
1.2		C=0,1 -0,25 annealed, short chip.	420	125					120 - 180
2.1		C=0,25 -0,55 annealed, long chip.	620	190					120 - 180
2.2		C=0,25 -0,55 annealed, short chip.	640	190	-	-	-	-	120 - 180
3		C=0,25 -0,55 tempered	850	250					120 - 180
4	C=0,25 -0,8 annealed	915	270					120 - 180	
5	C=0,25 -0,8 tempered	1020	300					120 - 180	
6	Low-alloy steel	annealed	610	180					90 - 140
7	Cast steel	tempered	930	275	-	-	-	-	90 - 140
8	Machining steel	tempered	1020	300					90 - 140
9		tempered	1190	350					90 - 140
10	High-alloy steel Cast steel	annealed	680	200					70 - 110
11	High-alloy tool steel	hardened and tempered	1100	325					70 - 110
12 - 13	Stainless steel and cast steel	ferritic/martensitic annealed martensitic	680 810	200 240	-	-	-	-	60 - 90 60 - 90
14.1	Stainless steel	austenitic quenched	610	180		40 - 60	40 - 80	40 - 80	80 - 220
14.2		austenitic/ferritic (duplex)	880	260		40 - 60	40 - 80	40 - 80	80 - 220
15	Grey cast iron	perlitic/ferritic		180	80 - 140	80 - 140	100 - 200	100 - 200	60 - 200
16		perlitic (martensitic)		260	80 - 140	80 - 140	100 - 200	100 - 150	60 - 200
17	Cast iron with nodular cast iron	perlitic		160	60 - 100	80 - 120	80 - 140	80 - 140	100 - 170
18		perlitic		250	60 - 100	80 - 120	80 - 140	80 - 140	100 - 170
19	Malleable cast	ferritic		130		60 - 120	80 - 140	80 - 140	60 - 100
20		perlitic		230		60 - 120	80 - 140	80 - 140	60 - 100
21	Aluminium	not heat treatable		60	80 - 400	100 - 500			
22	Forging alloys	heat treatable/ heat treated		100	80 - 400	100 - 500			
23	Aluminium Casting alloys	<12% Si not heat treatable		75	80 - 400	100 - 500			
24		<12% Si heat treatable/ heat treated		90	80 - 400	100 - 500			
25		>12% Si not heat treatable		130	80 - 400	100 - 500			
26	Copper	machined alloys, Pb>1%		110	80 - 300	100 - 300			
27	Copper alloys (bronze, brass)	CuZn, CuSnZn		90	80 - 300	100 - 300			
28		Cu, lead free copper/electrolyte copper		100	80 - 300	100 - 300			
29	Non metallic materials	Duroplastic							
30		Reinforced materials							
31	Heat resistant alloys	Fe-based annealed		200		30 - 80	30 - 90	30 - 100	40 - 100
32		Fe-based heat treated		230		30 - 80	30 - 90	30 - 100	40 - 100
33		Ni- or Co-based annealed		250		30 - 80	30 - 90	30 - 100	40 - 100
34		Ni- or Co-based heat treated		350		30 - 80	30 - 90	30 - 100	40 - 100
35		cast		320		30 - 80	30 - 90	30 - 100	40 - 100
36	Titanium alloys	Pure titanium	400						40 - 100
37		Alpha-beta alloys	1050						40 - 100
38	Hardened steels			50 - 62					
39				50 - 62					

t = dry machining  
n = wet machining



Cutting speed  $v_c$  in m/min

P10 bright	P10 bright	P40 S	P40 A	P40 Proton	CBN 1023	CBN 1024	CBN 1026	CBN 2026	CBN 2028	CBN 3018	PCD Grain middle
80 - 120	60 - 100	100 - 140	120 - 160	100 - 160							
80 - 120	60 - 100	100 - 140	120 - 160	100 - 160							
80 - 120	60 - 100	100 - 140	120 - 160	90 - 150							
80 - 120	60 - 100	100 - 140	120 - 160	100 - 160	-	-	-	-	-	-	-
80 - 120	60 - 100	100 - 140	120 - 160	90 - 150							
80 - 120	60 - 100	100 - 140	120 - 160	80 - 140							
80 - 120	60 - 100	100 - 140	120 - 160	75 - 120							
-	-	90 - 130	60 - 100	90 - 140							
-	-	90 - 130	60 - 100	60 - 110	-	-	-	-	-	-	-
-	-	90 - 130	60 - 100	60 - 110							
-	-	90 - 130	60 - 100	60 - 110							
-	-	60 - 100	60 - 100	60 - 110	-	-	-	-	-	-	-
-	-	60 - 100	60 - 100	50 - 90							
-	-	40 - 80	40 - 80	40 - 90	-	-	-	-	-	-	-
-	-	40 - 80	40 - 80	40 - 90							
-	-	-	-	-	-	-	-	-	-	-	-
-	-	-	-	-	200 - 600	200 - 600	200 - 600	200 - 600	200 - 600	750 - 1100 t	-
-	-	-	-	-	200 - 600	200 - 600	200 - 600	200 - 600	200 - 600	750 - 1100 t	-
-	-	-	-	80 - 130	-	-	-	-	-	-	-
-	-	-	-	-							
-	-	-	-	90 - 150	-	-	-	-	-	-	-
-	-	-	-	80 - 140							
-	-	-	-	-	-	-	-	-	-	-	900 - 3000
-	-	-	-	-	-	-	-	-	-	-	900 - 3000
-	-	-	-	-	-	-	-	-	-	-	600 - 2400
-	-	-	-	-	-	-	-	-	-	-	600 - 2000
-	-	-	-	-	-	-	-	-	-	-	300 - 700
-	-	-	-	-	-	-	-	-	-	-	400 - 1300
-	-	-	-	-	-	-	-	-	-	-	400 - 1300
-	-	-	-	-	-	-	-	-	-	-	400 - 1300
-	-	-	-	-	-	-	-	-	-	-	200 - 1000
-	-	-	-	-	-	-	-	-	-	-	200 - 1000
-	-	-	-	-	-	-	-	-	-	-	-
-	-	-	-	-	-	-	-	-	-	-	-
-	-	-	-	-	100 - 140 t	120 - 180 t	120 - 180 t	120 - 180 n	120 - 180 n	-	-
-	-	-	-	-	110 - 240 t	180 - 280 t	180 - 280 t	180 - 230 n	180 - 280 n	-	-

# HSC face milling cutters

<b>Guhring no.</b>	<b>3016</b>
<b>Standard</b>	<b>Guhring std.</b>
<b>Tool material</b>	<b>PCD-tipped</b>
<b>Surface</b>	<b>bright</b>
<b>Type</b>	<b>PF 1000 G</b>
<b>Cutting direction</b>	<b>right-hand</b>
<b>Discount group</b>	<b>110</b>

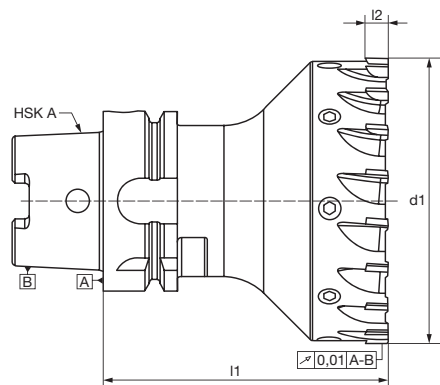

d1	HSK-A	l1	l2	Z	Code no.
mm		mm	mm		
32.000	63	100.00	8.00	8	32.000
40.000	63	100.00	8.00	10	40.000
50.000	63	100.00	8.00	12	50.000
63.000	63	100.00	8.00	14	63.000
80.000	63	100.00	8.00	16	80.000
100.000	63	100.00	8.00	18	100.000
125.000	63	100.00	8.00	22	125.000

Availability
--------------

- 
- 
- 
- 
- 
- 
-









# PF 1000 face milling cutter

**A unique solution offering outstanding performance, quality and economic efficiency**

Guhring's PF 1000 face milling cutter is the ideal tool for the economic high speed machining of non-ferrous metals such as aluminium, aluminium-alloys and copper.

The face milling cutter is available in diameters from 63 to 250 mm and holds 3 to 20 PCD milling inserts, depending on diameter.

For the PF 1000 face milling cutter to satisfy the extreme demands of HSC, Guhring has developed several leading technical innovations. They include the following:



### Innovative clamping screw locator

The utility patented steel ring for locating the clamping screws is shrunk into the milling body and provides the face milling cutter with exceptional rigidity allowing extremely high maximum revolutions, for example 26,875 rev./min. for a diameter of 100 mm.

### Integrated threads for PCD milling inserts

The threads for locating the PCD milling inserts are integrated in the clamping wedges. Therefore, clamping threads or threaded inserts are not required in the milling body, uneven clamping through the wedging effect no longer occurs. The internal screwhead reduces the centrifugal forces and concentrates the mass near to the rotational axis.

### Integrated chip deflectors

The steel chip deflectors integrated in the clamping wedge provide optimal protection for the milling body and guarantee extremely long tool life.

### Utility patented wedge clamping

The positive fit of the utility patented wedge clamping guarantees a secure clamping of the PCD milling insert even at extreme speeds and therefore above average milling quality and performance.



**Diagram 1:**

Feed rate for example  $f=0.1$  mm/tooth

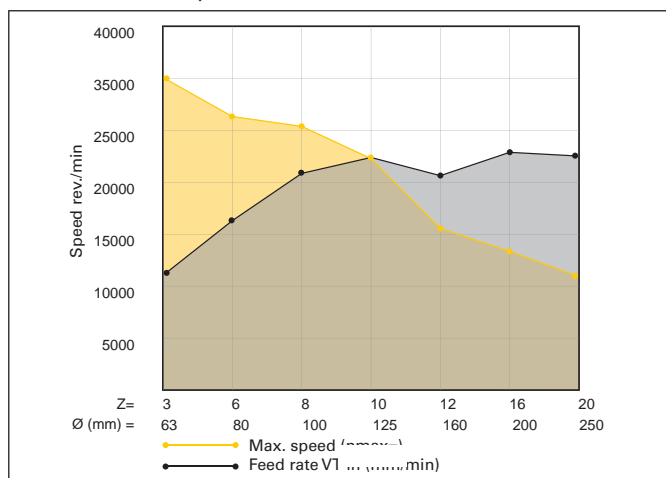

**Diagram 2:**

Max. speed dependent on tool diameter

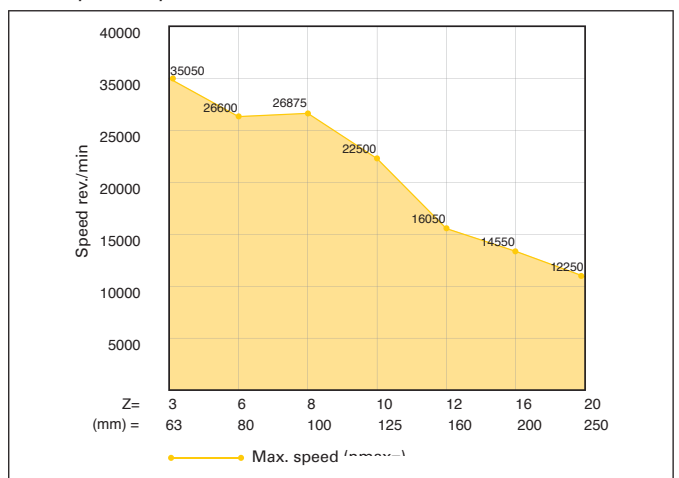

# PF 1000 face milling cutter

Many sophisticated individual solutions provide a unique system for HSC milling of non-ferrous metals such as aluminium and copper, including the following:

**Utility patented, axial wedge adjustment**

for the adjustment of the PCD milling insert of up to 1 mm via a 15° wedge, provides very accurate setting possibilities. The adjusters are precisely integrated into the milling cutter body.

**Milling arbor:**

from Guhring's GM 300 range, specially optimised with an increased bearing surface for Ø 200 mm and Ø 250 mm face milling cutters.

**A high-tensile aluminium clamping disc** from face milling cutter diameter 160 mm ensures a perfect fit of the milling body even at highest speeds and also includes an optimised central coolant delivery for minimal quantity lubrication (MQL).



**High-tensile, high-quality screws** ensure secure clamping of the milling body to the milling arbor.



**Balancing screws** for precision balancing with locking threads.

**Milling body with special surface finish** produced in high-tensile aluminium for reasons of reducing mass from Ø 100 mm. This reduces the forces on the machine spindle bearings for high speed machining. The utility patented, steel ring for locating the clamping screws is shrunk into the milling body.

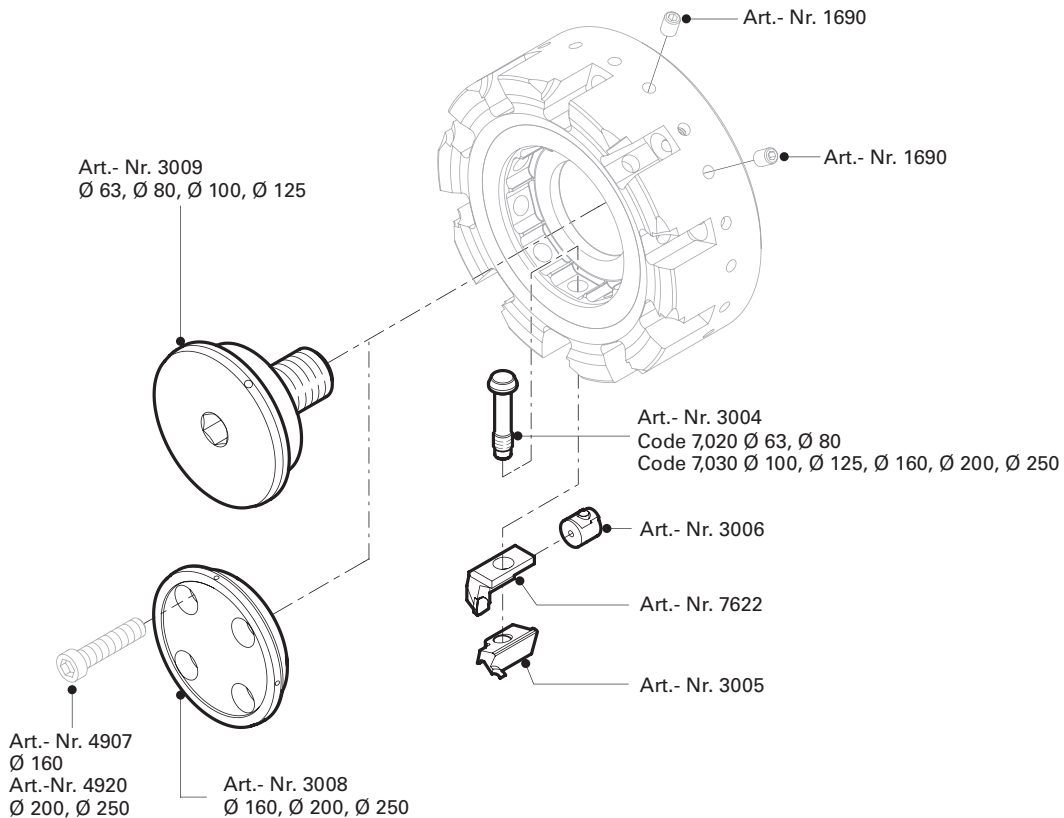





# Face milling insert

<b>Guhring no.</b>	<b>7622</b>	<b>7623</b>
<b>Standard</b>	<b>Guhring std.</b>	
<b>Tool material</b>	<b>PCD</b>	<b>CBN</b>
<b>Surface</b>	<b>bright</b>	<b>bright</b>
<b>Cutting direction</b>	<b>rh</b>	<b>rh</b>
<b>Discount group</b>	<b>114</b>	<b>114</b>

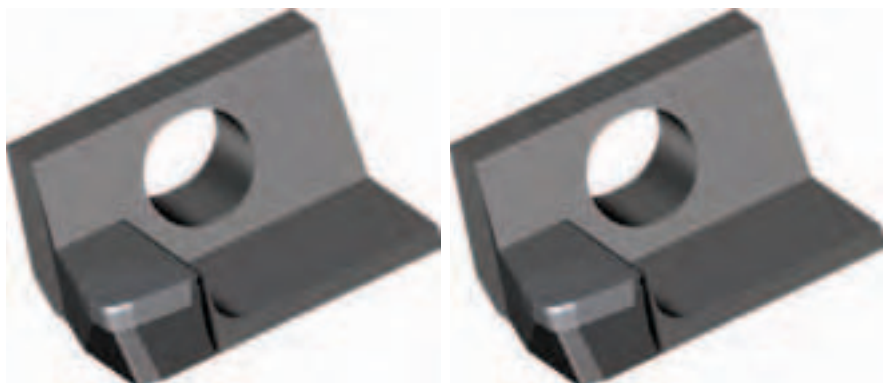
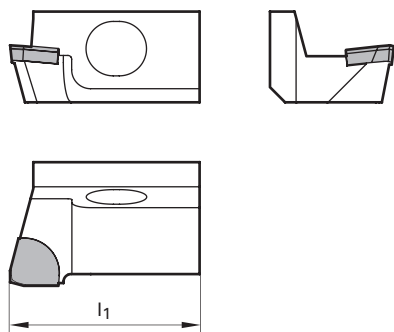

d1	Code
mm	
25.00	75,000

<b>Availability</b>	
●	on request

## Basic holders

<b>Guhring no.</b>	<b>3002</b>	<b>3003</b>
<b>Standard</b>	<b>Guhring std.</b>	
<b>Discount group</b>	<b>114</b>	<b>114</b>



d1	d3	outer Ø	l1
mm	mm	mm	mm
63.000	22.000	61.800	43.10
80.000	27.000	78.800	48.10
100.000	32.000	98.500	48.10
125.000	40.000	123.500	48.10
160.000	40.000	158.500	61.10
200.000	60.000	198.500	61.10
250.000	60.000	248.500	61.10

<b>Availability</b>	
●	●
●	
●	
●	
●	

# Clamping wedge

<b>Guhring no.</b>	<b>3005</b>
<b>Standard</b>	<b>Guhring std.</b>
<b>Discount group</b>	<b>114</b>

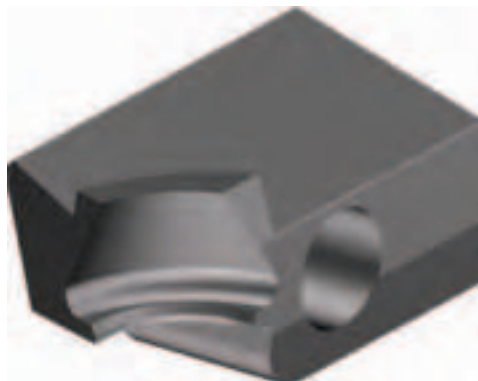

Code-Nr.
7,000

Availability
●

# Retention screws

<b>Guhring no.</b>	<b>3009</b>
<b>Standard</b>	<b>Guhring std.</b>
<b>Discount group</b>	<b>114</b>

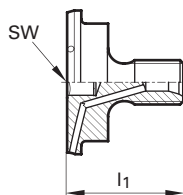

G	l1	SW	Code
	mm		
M10	44.50	6.00	63,000
M12	49.50	8.00	80,000
M16	52.60	10.00	100,000
M20	52.50	12.00	125,000

Availability
●
●
●
●

# Clamping discs

<b>Guhring no.</b>	<b>3008</b>
<b>Standard</b>	<b>Guhring std.</b>
<b>Discount group</b>	<b>114</b>



Code	Availability
160,000	●
200,000	●
250,000	●

## Adaptors

<b>Guhring no.</b>	<b>3004</b>
<b>Standard</b>	<b>Guhring std.</b>
<b>Discount group</b>	<b>114</b>

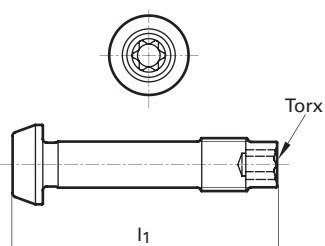

Torx	l1	Code	Availability
	mm		
T25	23.50	7,020	●
T25	35.00	7,030	●

# Adjustment units

<b>Guhring no.</b>	<b>3006</b>
<b>Standard</b>	<b>Guhring std.</b>
<b>Discount group</b>	<b>114</b>

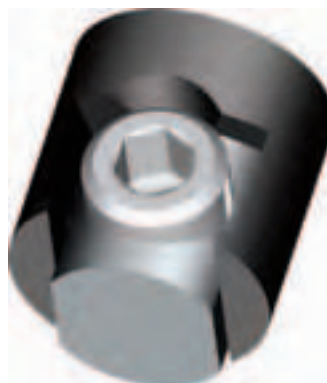

Code
11,000

Availability
● ● ●

# Hexagon socket clamping screws

<b>Guhring no.</b>	<b>4920</b>	<b>4907</b>
<b>Standard</b>	<b>DIN 6912</b>	<b>DIN EN ISO 4762</b>
<b>Discount group</b>	<b>114</b>	<b>114</b>

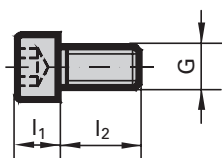

G	l1	l2	SW	Code
	mm	mm		
M12	12.00	65.00	10.00	12,650
M16	10.00	70.00	14.00	16,700

Availability
●

# Hexagon socket sets

<b>Guhring no.</b>	<b>4916</b>
<b>Standard</b>	<b>Guhring std.</b>
<b>Discount group</b>	<b>114</b>

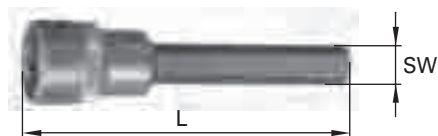

Drive	L	SW	Code
inch	mm		
1/2	90.00	6.00	6,038
1/2	90.00	8.00	8,048
1/2	140.00	10.00	10,060
1/2	140.00	12.00	12,000
1/2	60.00	14.00	14,000

Availability	
	●
	●
	●
	●
	●

# Locking threaded pins

<b>Guhring no.</b>	<b>1690</b>
<b>Standard</b>	<b>Guhring std.</b>
<b>Discount group</b>	<b>114</b>

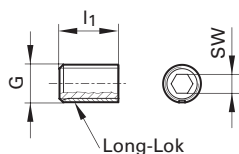

G	L	SW	Code
	mm		
M6	8,00	3,00	6,001
M6	12,00	3,00	6,002

Availability	
	●
	●

# Hexagon allen keys

**Guhring no.**

**4921**

**Standard**

**Guhring std.**

**Discount group**

**114**

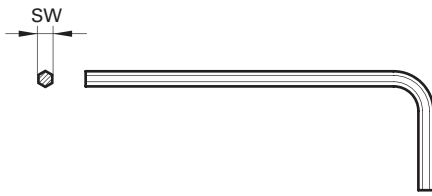

SW	Code
3.00	3,000

Availability
●

# TECHNICAL SECTION





$$n = \frac{v \cdot \rho \cdot \pi \cdot D}{10}$$

$$v = \frac{2}{n}$$

$$v = n \cdot \Sigma$$



## Natural diamond: The Wonder of nature

They are one of the most fascinating and most valuable raw materials in the world. Infinitely hard and with wear-resistance and sharpness that can hardly be surpassed: Diamonds.

Many hundred million years ago, diamonds crystallised hundreds of kilometres below the earth's surface through the synthesis of pure carbon and graphite at in excess of 1,000 degrees Celsius and at a pressure of in excess of 40,000 bar.

Created by complex chemical processes under unusual conditions diamonds have had – due to their outstanding properties and their rarity – an enormous value for centuries.

The hardest mineral stone on earth, diamonds possess highly functional properties that also the industry wanted to utilise. It was successfully achieved for the first time in the 50's – and revolutionised the machining industry.



*Impressive  
Ajchal diamond mine in Russia, a rich source for diamonds*

## Polycrystalline diamond PCD: Superlative tool material

Synthetic PCD is created by connecting diamond particles and a carbide substrate under extreme heat and a pressure of several ten thousand bar. Under these conditions the cobalt from the carbide substrate penetrates the coating of the diamond powder and creates an intensive fusion of the diamond particles.

A synthetic twin having the hardness and the wear-resistance of diamond is created. PCD has developed into the superlative tool material and there is no competitor for machining non-ferrous materials with anywhere near the outstanding machining properties.

The high wear-resistance enables long tool life, efficient cutting data, short cycle times and high feed rates.

In the past 30 years Guhring has continuously developed its know-how regarding the manufacture of PCD tools.

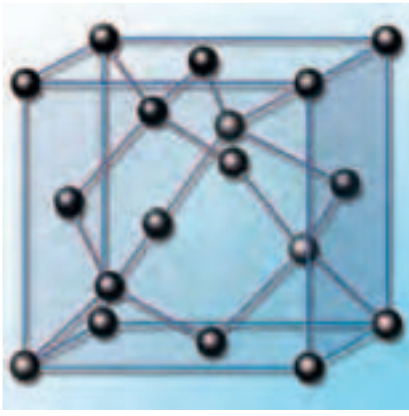

*Structure  
Easily recognisable – the cubic structure*



*Valuable raw material  
Raw diamonds cleansed from accompanying minerals and dirt*

## Values for cutting speeds

Following you will find cutting rates for rotary machining. These are guide values and should serve as an orientation. The values can be further adapted following the initial assessment of the machining result in order to achieve optimal quality and cycle time.

Reaming allowance 0.3 mm – 2 mm

Material	Cutting speed $v_c$ (m/min)	Cutting feed $f_z$ (mm)
Al wrought alloys	200 - 400	0.05 - 0.25
Al cast alloys < 9 % Si	200 - 800	0.05 - 0.2
Al cast alloys up to 12 % Si	300 - 600	0.05 - 0.2
Al cast alloys up to 17 % Si	200 - 400	0.05 - 0.2
Magnesium wrought alloys	250 - 400	0.05 - 0.25

## Drilling

Material	Cutting speed $v_c$ (m/min)	Cutting feed $f_z$ (mm)
Al wrought alloys	200 - 500	0.08 - 0.25
Al cast alloys < 9 % Si	350 - 800	0.08 - 0.15
Al cast alloys up to 12 % Si	350 - 800	0.08 - 0.15
Al cast alloys up to 17 % Si	200 - 400	0.08 - 0.15
Magnesium wrought alloys	400 - 600	0.05 - 0.15

## Milling

Material	Cutting speed $v_c$ (m/min)	Cutting feed $f_z$ (mm)
Al wrought alloys	700 - 3000	0.05 - 0.3
Al cast alloys < 9 % Si	250 - 900	0.05 - 0.25
Al cast alloys up to 12 % Si	250 - 900	0.05 - 0.2
Al cast alloys up to 17 % Si	700 - 2000	0.05 - 0.2
Magnesium wrought alloys	700 - 2000	0.05 - 0.2

Module alignment adapter  
4x4 and 6x6



## Guhring modules Spot-on tool setting

Guhring modules 6x6 and 4x4 are the perfect solution for a quick, simple and  $\mu$ -accurate setting of tools in highly precise manufacturing areas such as fine machining.

### The advantages for the user:

- up to 70% time saving in tool pre-setting
- cost reduction
- highly accurate, wobble-free tool setting
- an extremely solid and rigid connection
- cooling lubricant delivery without loss or flow disruption

Whilst Module 4x4 is the market compatible solution the Guhring Module 6x6 is providing further opportunities for modular technology to satisfy the highest demands. On Guhring's Module 6x6 the setting screws for radial and axial setting sit much closer to each other than on conventional modules. This allows the elimination of errors in close proximity to the measuring point – even with 6-fluted tools with pinpoint accuracy!

### 1 Length setting screw with axial force damping

For conventional cooling lubrication the new length setting screw with axial force damping can be applied in both modules. It ensures accurate, tension-free shrink fitting by preventing the tool shank deflecting through the axial pressure on the setting screw. It also ensures a perfect length setting of the tool.



### 2 Positioning mark

Both modules possess a positioning bore for the first tool cutting edge. It is in alignment with the first setting screws for the radial and axial setting of the module. This enables a quick and simple as well as optimal setting of the entire holder-module-tool system.

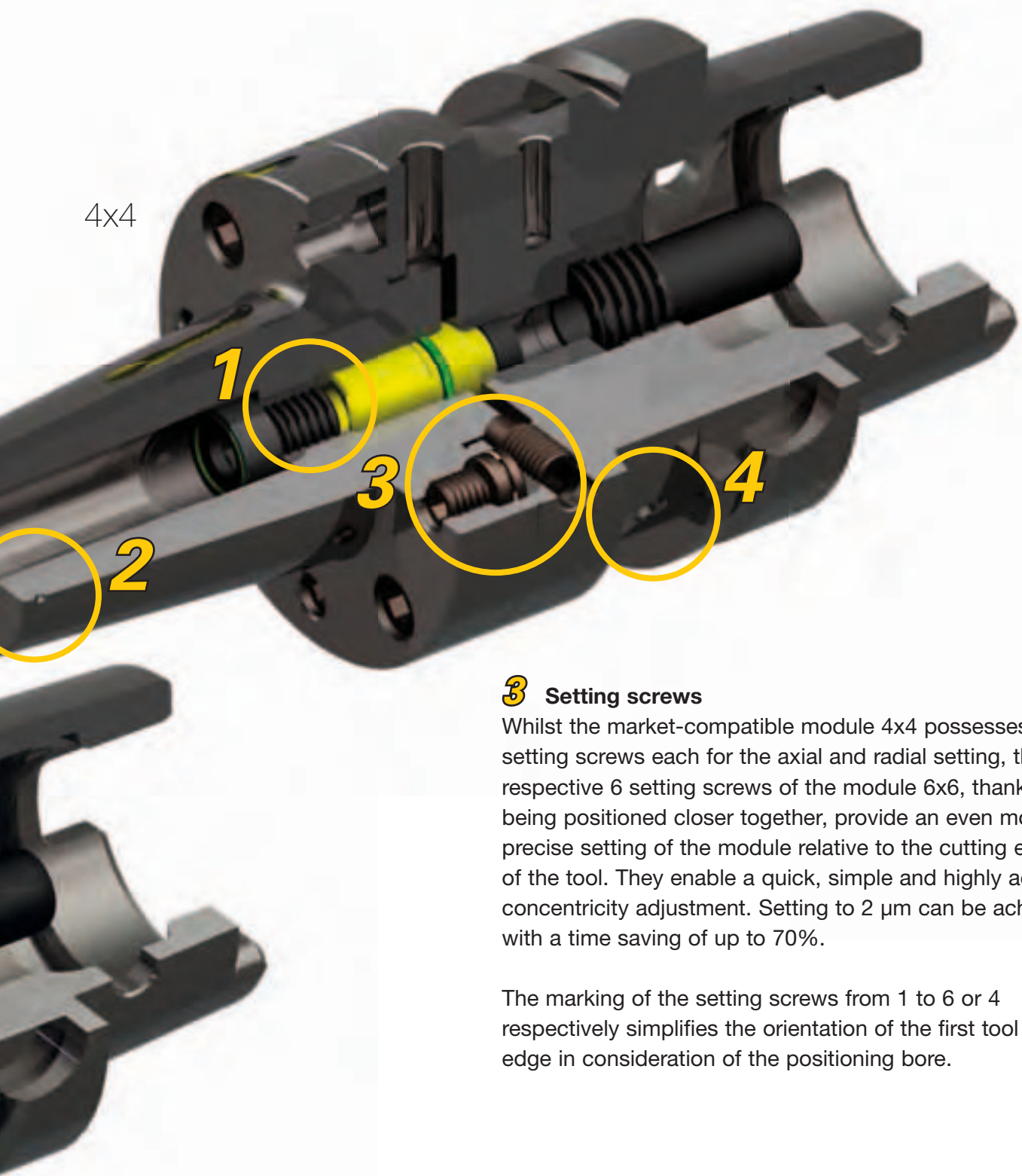

### **3** Setting screws

Whilst the market-compatible module 4x4 possesses 4 setting screws each for the axial and radial setting, the respective 6 setting screws of the module 6x6, thanks to being positioned closer together, provide an even more precise setting of the module relative to the cutting edges of the tool. They enable a quick, simple and highly accurate concentricity adjustment. Setting to 2 µm can be achieved with a time saving of up to 70%.

The marking of the setting screws from 1 to 6 or 4 respectively simplifies the orientation of the first tool cutting edge in consideration of the positioning bore.

### **4** Location bore for balancing screw

The module 6x6 as well as the module 4x4 possess 6 balancing bores. Thanks to being close to each other they enable a quick balancing in close proximity of the imbalance. The positioning of the balancing bores having a large effective diameter and thread depth provides a highly effective balancing capability.

## Gühring modules

### Optimal cooling lubricant delivery

The modules 6x6 and 4x4 have both been designed for conventional cooling lubrication as well as minimal quantity lubrication. Whatever type of cooling lubrication the user decides on,

the delivery system components required are 100% compatible. Subsequently, it is possible to convert any modules in stock without a problem.

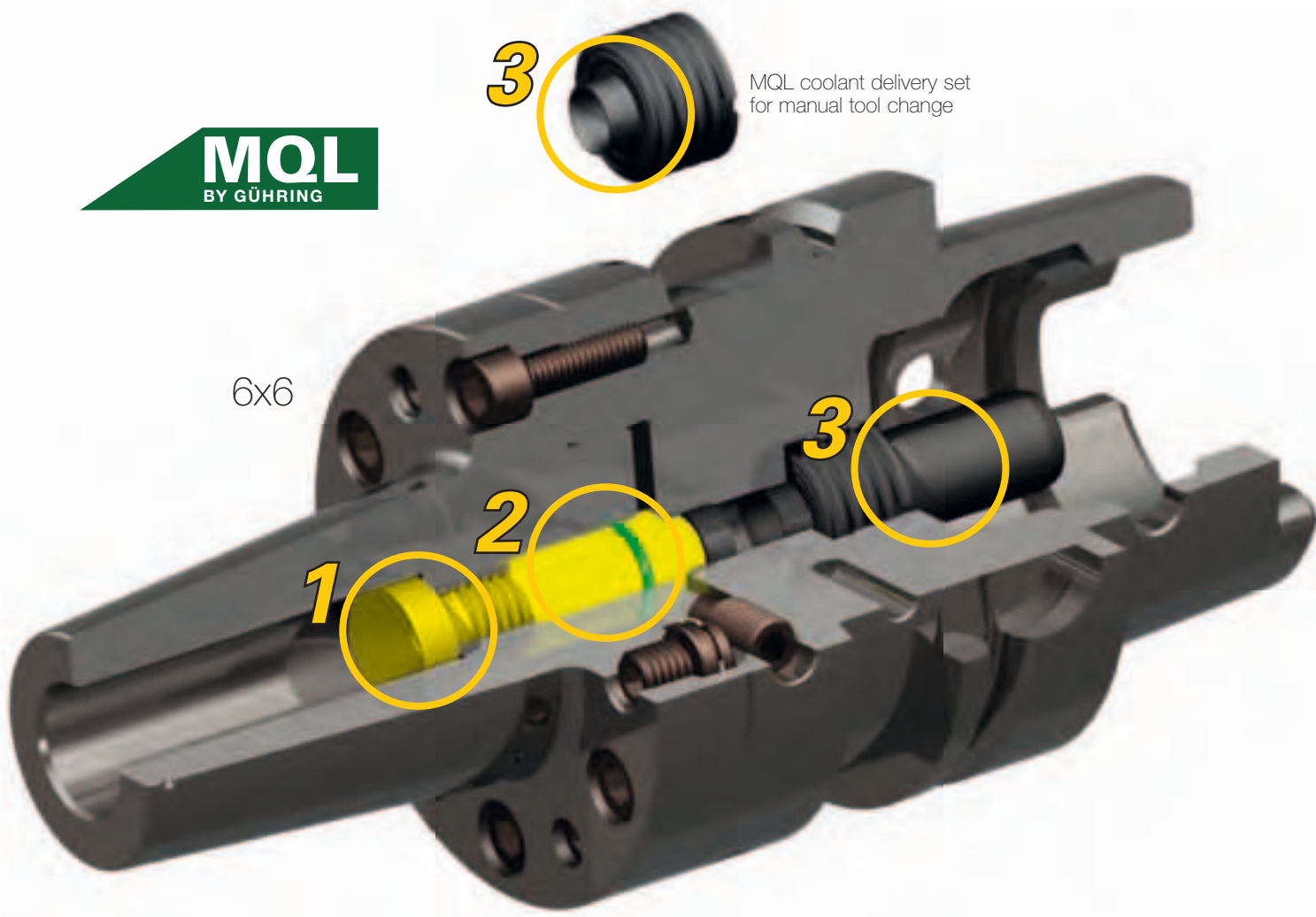

**MQL**  
BY GÜHRING

6x6

3

MQL coolant delivery set  
for manual tool change

3

2

1

#### **1** MQL length setting screw

The tool sits with its conical, MQL suitable shank end in the corresponding head shape of the MQL length setting screw. A sealing lip ensures a loss-free cooling lubricant delivery to the tool.





MQL coolant delivery set for manual tool change

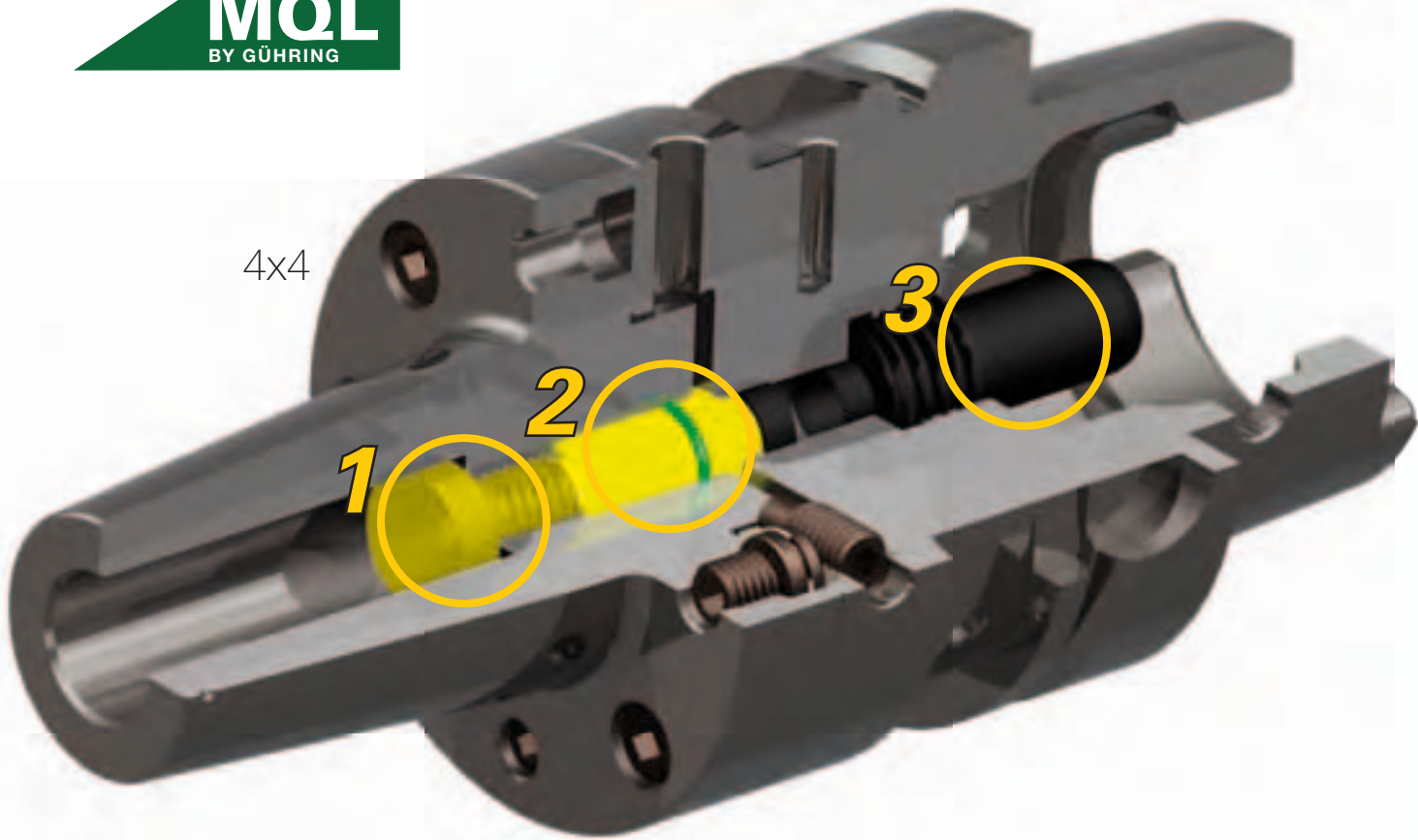

## 2 Delivery unit

The delivery unit feeds the cooling lubricant through the tool holder without dead areas. For this, it is fitted with an O-ring and a special sealing lip. Particularly with MQL machining, a loss-free coolant delivery in this area is decisive for an optimal delivery to the cutting edges.

## 3 MQL coolant delivery set, Guhring no. 4939 or 4940

A loss-free cooling lubricant delivery between spindle and tool holder is provided by MQL coolant delivery sets 4939 for automatic and 4940 for manual tool change.

### Coolant delivery set for conventional cooling lubrication, Guhring no. 4949

Alternatively, for conventional cooling lubrication the coolant delivery set 4949 is applied, that is 100% compatible with MQL coolant delivery sets.

## Gühring modules MQL without loss

Particularly with minimal quantity lubrication (MQL) the tool is of vital importance for an optimum and reliable machining process. the loss- and flow disruption-free delivery of minimal cooling lubrication quantities to the cutting edge of

### **Gühring's delivery system: MQL length setting screw and intermediate sleeve**

The cooling lubricant is supplied in a straight line without restriction or turbulence from the machine through the tool holder to the cutting edge. Gühring's delivery system can also be retro-fitted to other tool holders!

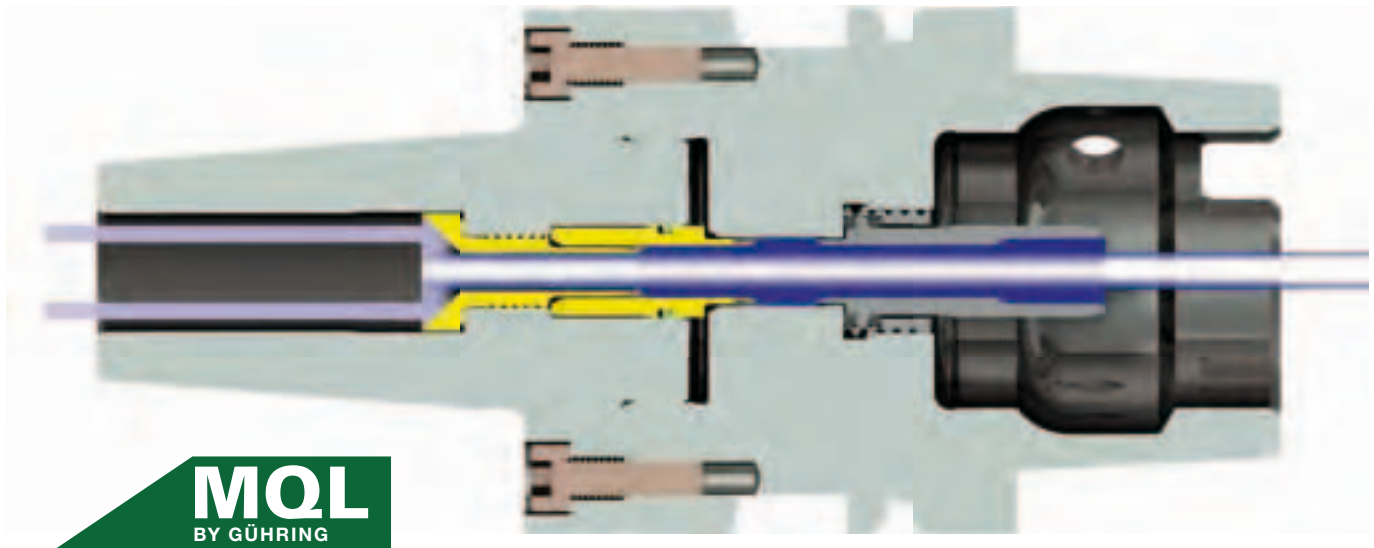

## Guhring modules

### Loss-free conventional cooling lubricant delivery and hydraulic tension

The benefits of Guhring's Modules are not only the quick, simple and highly-accurate tool setting. But the optimal cooling lubricant delivery

without restriction or turbulence ensures a perfect machining result thanks to loss-free cooling and lubrication of the tool's cutting edges.

#### **Guhring's delivery system for conventional cooling lubrication with intermediate sleeve**

The cooling lubricant is supplied in a straight line without restriction or turbulence from the machine through the tool holder to the cutting edge.

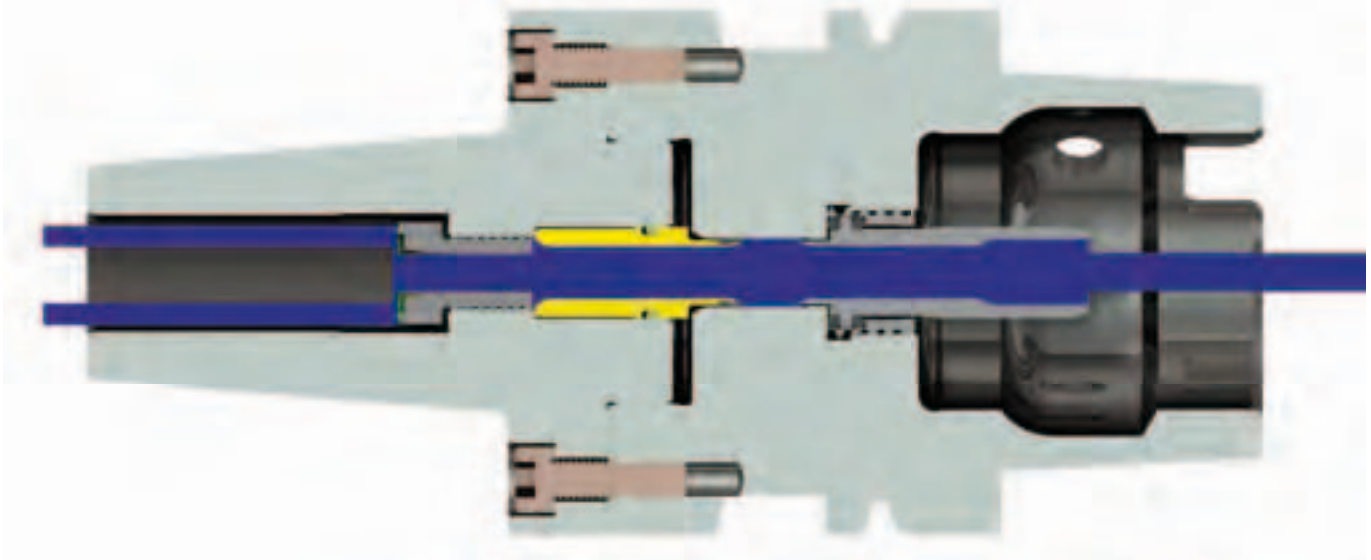

#### **Market conventional configuration without delivery system**

The cooling lubricant deflects in the tool holder and the coolant exits into and from hollow areas in the holder. In addition, the cooling lubricant exerts force on the piston surfaces due to the high pressure of about 80 bar resulting in hydraulic tension and concentricity errors.

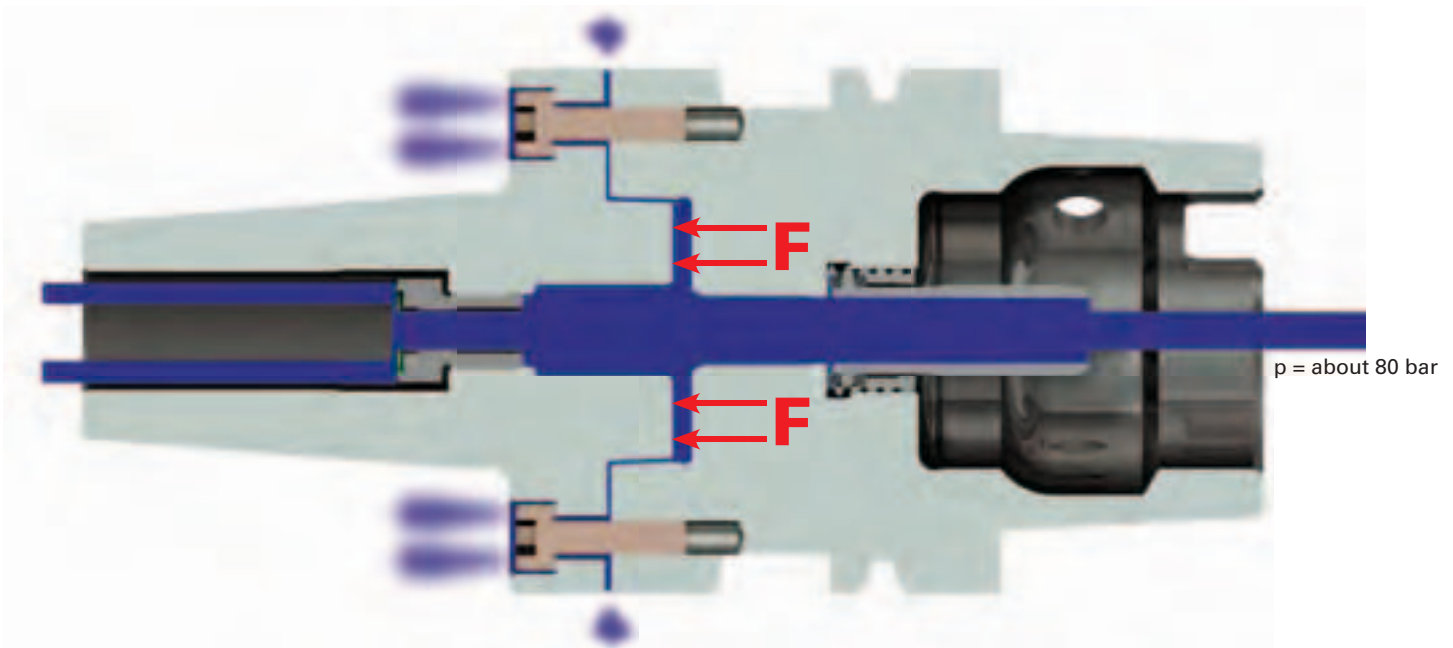

## Guhring modules

### Module 6x6 – the advantages at a glance

- quick and targeted  $\mu$ -accurate setting thanks to the close proximity of axial and radial setting screws to the error measuring point. Ideal for 6-fluted tools with a perfect fit to the cutting edge.
- quick and targeted balancing thanks to 6 deep balancing bores and threads providing a high balancing capacity.
- optimal setting results with multi-flute PCD/CBN fine machining tools or Guhring's HR 500 high performance reamer with 6 cutting edges.
- especially rigid connection thanks to 6 fastening screws.
- accurate wobble setting and optimal rigidity thanks to a high pre-clamping torque.
- minimal 'settlement behaviour' offering highest accuracy over a long application period.
- universal and modular designed system with hydraulic chucks, shrink fit chucks or HPC clamping chucks as well as HSK or SK interface.
- available in combination with monolithic special tools.

## Guhring modules

### Module 4x4 – the advantages at a glance

- market compatible module
- extensive range, of modular design
- optimal cooling lubricant throughput with conventional cooling as well as with MQL (optional)
- hydraulic chucks and shrink fit chucks with increased insertion depth to current Guhring standard for conical shank ends and long MQL shank

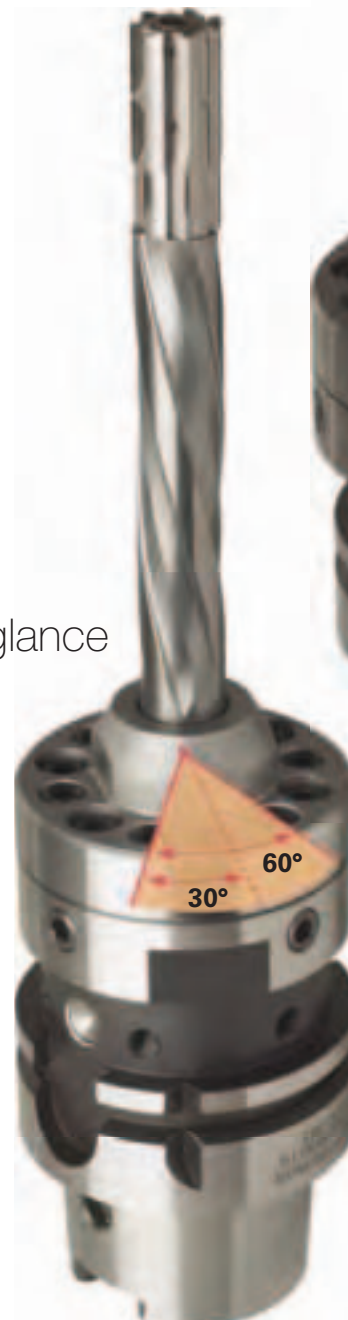

*Perfect fit:*  
With module 6x6 the error measuring point is a max. 30° away from the next positioning bore. The same applies to the balancing bore.

# Guhring modules

## Module system summary 6x6 and 4x4

### Alignment adaptor HSK-A

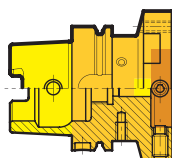

Alignment adaptor  
Guhring no. 4723

### SK alignment adaptor DIN 69871 AD/B

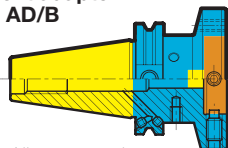

Alignment adaptor  
Guhring no. 4725

### Machine spindle Direct installation

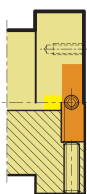

### Module 6x6



Intermediate tube  
Guhring no. 4716

### Module flange

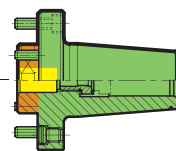

Shrink fit chucks  
Guhring no. 4717

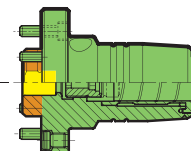

Hydraulic chucks  
Guhring no. 4722

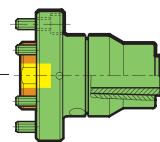

HPC clamping chucks  
Guhring no. 4714

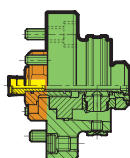

HSK adaptor (in front)  
Guhring no. 4363

### Alignment adaptor HSK-A

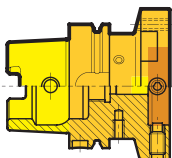

Alignment adaptor  
Guhring no. 4297

### SK alignment adaptor DIN 69871 AD/B

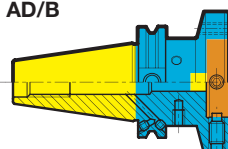

Alignment adaptor  
Guhring no. 4724

### Machine spindle Direct installation



### Module 4x4



Intermediate tube  
Guhring no. 4716

### Module flange

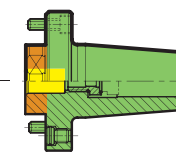

Shrink fit chucks  
Guhring no. 4760

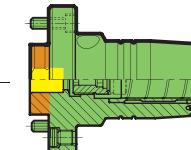

Hydraulic chucks  
Guhring no. 4360

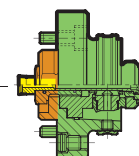

HSK adaptor (in front)  
Guhring no. 4713

## Setting and handling instructions GM 300 module 6x6 and 4x4

### 1. Assembly and radial alignment of module flange

1.1 Clean spigot diameter and plane faces of module flange and alignment adapter.

1.2 Insert module flange



Insert intermediate tube into the module flange bore up to the shoulder

- 1) Lightly lubricate the sealing lip
- 2) Carefully insert the sealing lip in centre of location bore in order to prevent damage. Then fit the module flange into the alignment adaptor.

1.3 Tighten the fastening screws to 50 % of the specified tightening torque (see “tightening torque” table).



1.4 Position dial gauge at the concentricity check point (ground module collar diameter). Record highest measuring point and “zero” the dial gauge.



- 1.5 Roughly align module flange (approx. 0.01 mm). Loosen the adjustment screws again following procedure.
- 1.6 Tighten fastening screws to specified torque. Then set the concentricity with the adjustment screws then loosen the adjustment screws again following procedure. Repeat the procedure until the concentricity error is  $\leq 3 \mu\text{m}$ . When the concentricity has been adjusted lightly tighten all the adjustment screws and check the concentricity again.

### Tightening torque

Module diameter	Fastening screw	Tightening torque
60 mm	DIN 912-M5x16-12.9	8.7 Nm
70 mm	DIN 912-M6x20-12.9	15.0 Nm
80 mm	DIN 912-M6x20-12.9	15.0 Nm
100 mm	DIN 912-M8x25-12.9	36.0 Nm
117 mm	DIN 912-M8x25-12.9	36.0 Nm
140 mm	DIN 912-M10x30-12.9	72.0 Nm

## 2. Angular alignment of module flange



- 2.1 For the angular alignment the dial gauge is positioned at the front concentricity check point, at the cutting edge guiding pads or at a suitable position. Use the alignment screws to perform the angular alignment. Following the above procedure do not loosen the alignment screws.
- 2.2 When the angle alignment is adjusted to  $\leq 3 \mu\text{m}$ , check the radial alignment at the concentricity check point on the module collar again and correct if necessary. If the radial alignment has to be corrected, the angle alignment will have to be checked again.





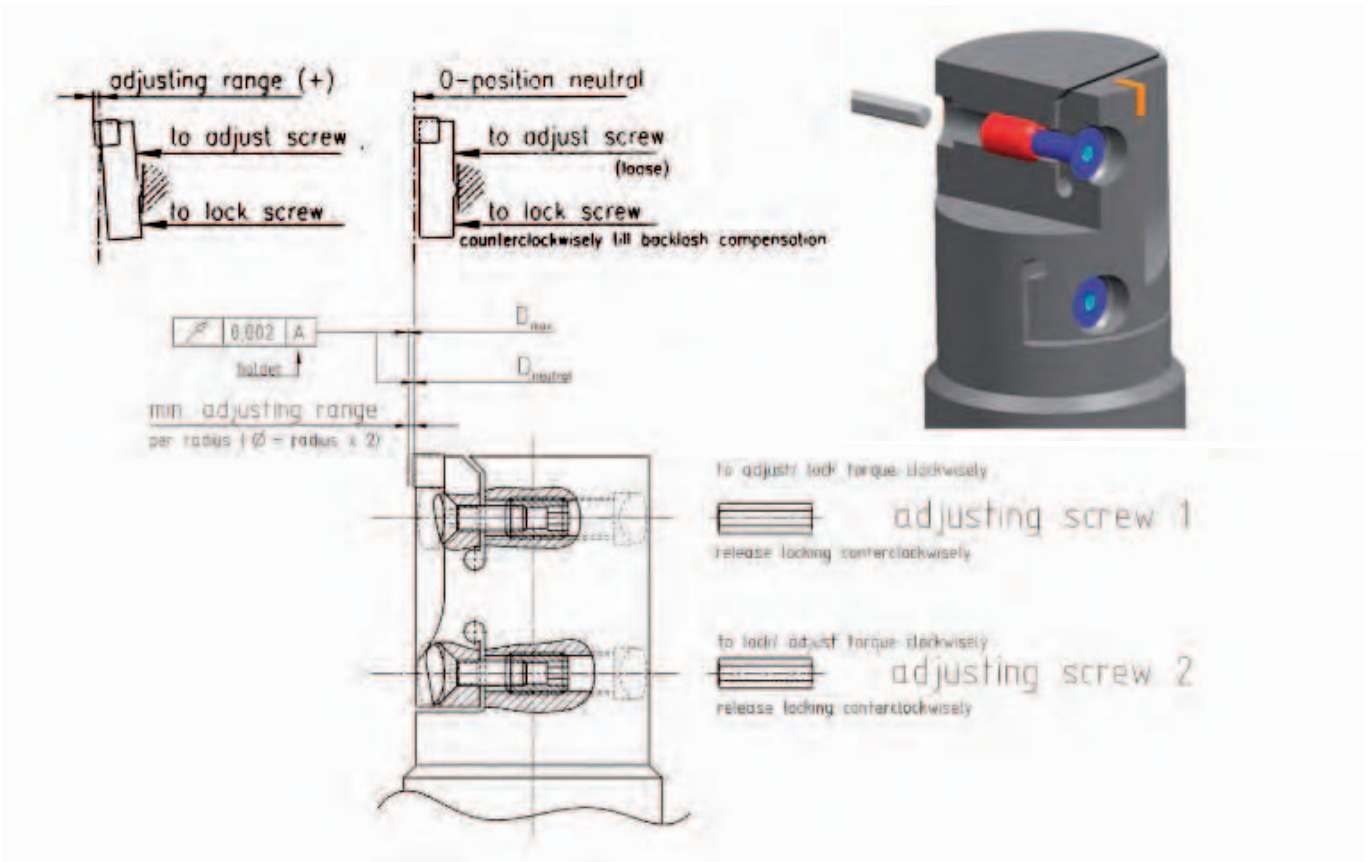

Application for example at a PCD-Step reamer

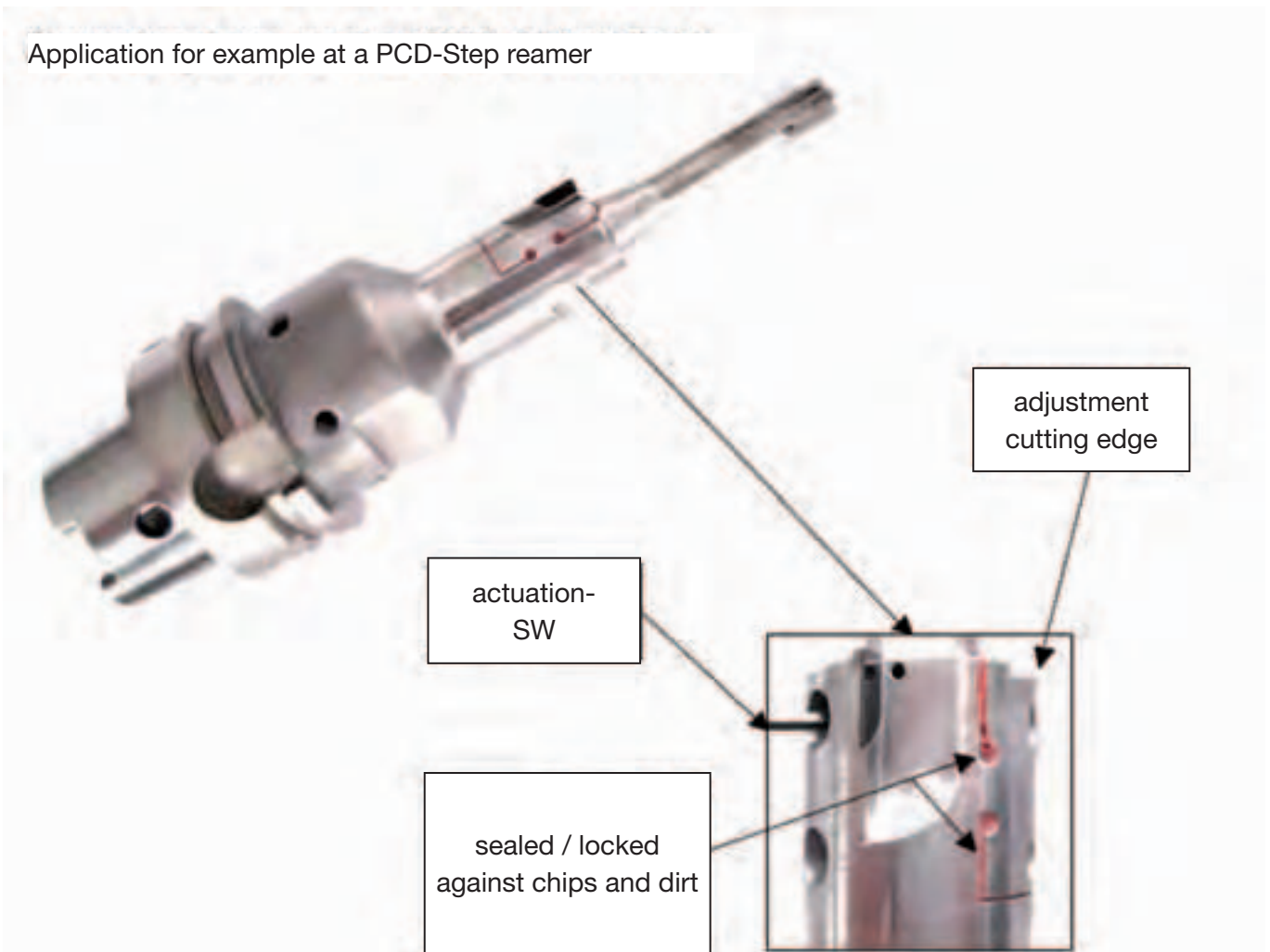

## Setting and handling notes

### Expansion screw

#### **Coolant delivery directly to the cutting edges via expansion screw**

- Quick, simple and highly accurate setting of the first tool step diameter.
- Radial delivery of the coolant directly at the cutting edges via expansion screw.
- Optimal tool lubrication.
- Optimal chip evacuation from the hole.

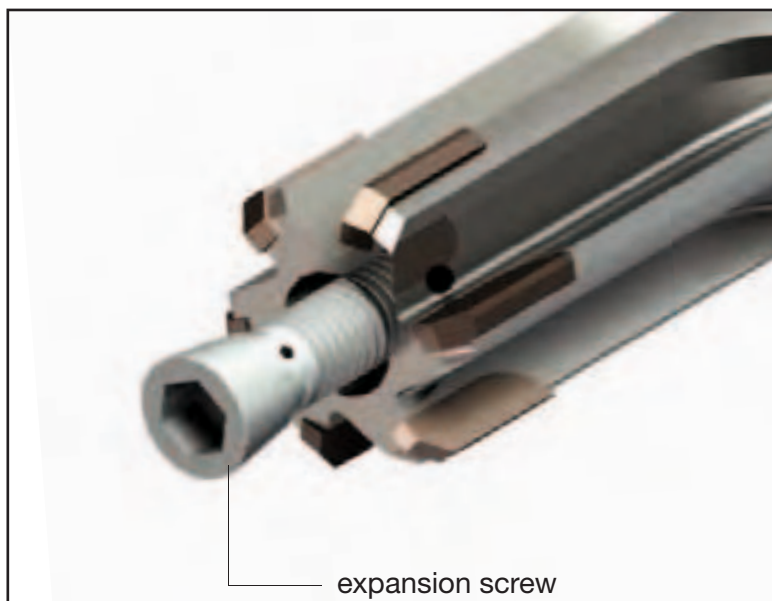

$\mu\text{m}$ -accurate adjustment of the diameter is possible by turning the expansion screw. The adjustment range is max. 0.02 mm.

For reaming operations with PCD- or CBN-tipped tools, Guhring has developed unique solutions opening up completely new possibilities regarding accuracy and economic efficiency. Reaming tools with these technologies offer the user the following clear competitive advantages:

- simple, quick and highly accurate diameter setting for first and second step.
- both tool diameters can be re-adjusted when tool is in clamped condition.
- machining of through and blind holes thanks to the integrated expansion screw in the tool point.
- optimal coolant delivery to the cutting edges thanks to radial coolant exits in the expansion screw.
- highest feed rates thanks to several cutting edges.
- reduction in machining time.
- maximum accuracy and extreme tool life.

# Setting and handling notes

## GP 100

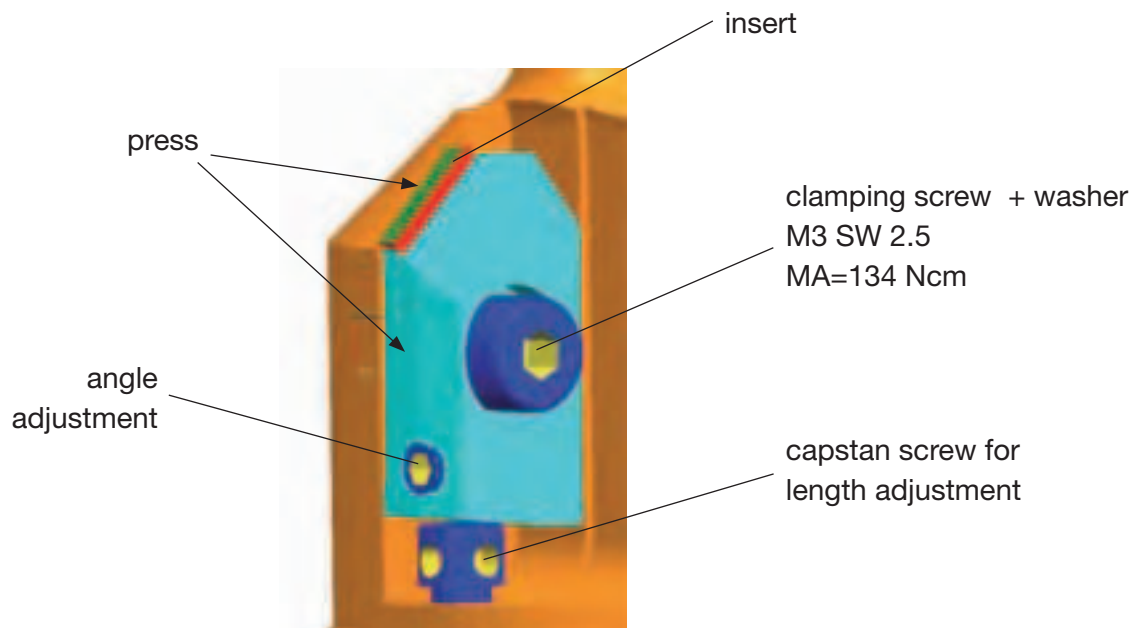

The angle to the centre axis is manufactured  $0.5^\circ$  smaller than the corresponding nominal dimension and possesses a  $+1^\circ$  adjustment range.

The clamping claw is adjustable in length by  $\pm 0.2\text{mm}$  from the nominal dimension.

Tools are supplied pre-set.

When replacing the indexable insert proceed as follows:

- Loosen length setting screw and angle setting screw by half a turn
- Loosen / dismantle clamping.
- Clean and assemble components, lightly oil clamping screw.
- Gently tighten clamping screw (approx. 20 Ncm). While doing so press indexable insert and clamping claw in direction of arrow with thumb and index finger.
- Angle setting to  $0.1^\circ$  ahead of nominal dimension
- Length setting to 0.05 less than nominal dimension
- Angle setting to nominal dimension
- Tightening clamping screw to 134 Ncm
- Length setting to nominal dimension

## Setting and handling notes

### TWA (threaded wedge adjustment) for direct installation of indexable inserts

#### A. ASSEMBLY

1. Lightly lubricate the bottom and the walls of the location bore of the TWA as well as the thread of the setting screw with MOS2 assembly paste.
2. Locate the hexagonal key through the wedge into the setting screw and insert together into the base of the location bore of the adjustment unit (fig.1).
3. Using the hexagonal key push the setting screw into the radial recess at the base of the bore and screw-in the wedge anticlockwise. When doing this the indexable insert contact surface on the wedge must be positioned towards the indexable insert seat (push the wedge from above onto the setting screw, so that the thread of the wedge can locate onto the setting screw). If when screwing in the wedge the collar of the setting screw "jams" in the location bore (noticeable through the setting screw being difficult to turn), push the entire adjustment unit fully into the location bore with the hexagonal key, if necessary resolve "jam" via clockwise rotation (fig. 2).
4. Lightly lubricate the indexable insert contact surface on the wedge with MOS2 assembly paste and screw in indexable insert in clockwise direction into the indexable insert seat with indexable insert clamping screw (lightly lubricate thread).
5. The disassembly is carried out in the reverse order.

#### B. OPERATION:

1. Using a Torx key lightly tighten the indexable insert clamping screw in a clockwise direction to the smallest diameter setting (wedge and setting screw).
2. Adjust indexable insert to 0.05 mm of diameter before the final dimension: Insert the hexagonal key in the setting screw and adjust the diameter in clockwise direction (fig. 3). Then tighten the indexable insert clamping screw to the specified tightening torque.
3. Adjust the indexable insert to the final dimension.
4. If the diameter has already been exceeded, loosen the adjustment in anti-clockwise direction until the wedge noticeably loosens and re-adjust in clockwise direction. To do this the indexable insert clamping screw does not require loosening.
5. When replacing the indexable insert or when required lubricate the contact surfaces and the thread of the TWA adjustment unit with MOS2 assembly paste.

#### C. TIGHTENING TORQUE INDEXABLE INSERT CLAMPING SCREWS:

Thread size	Torx size	Tightening torque
M 4 / M 4x0,5	Torx 15	515 Ncm
M 3,5	Torx 15	345 Ncm
M 2,5	Torx 8	128 Ncm
M 2,2 / M 2,5	Torx 7	101 Ncm

#### D. KEY SIZES OF THE TWA ADJUSTMENT UNITS AND THE ADJUSTMENT TRAVEL OF THE INDEXABLE INSERTS:

Indexable insert size	Hexagonal socket	Indexable insert adjustment travel in radius (at 1/4 rotation of setting screw)
0602..	SW 1,5	0.015 mm with indexable insert with 7° clearance angle or 0.024 with indexable insert with 11° clearance angle
09T3..	SW 2,0	
1204..	SW 3,0	

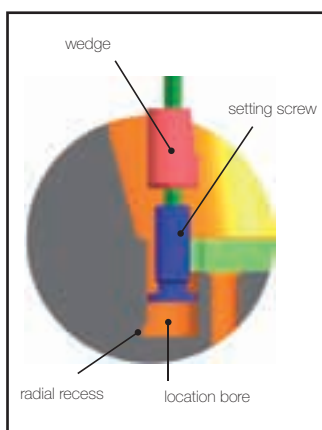

Fig. 1: ASSEMBLY

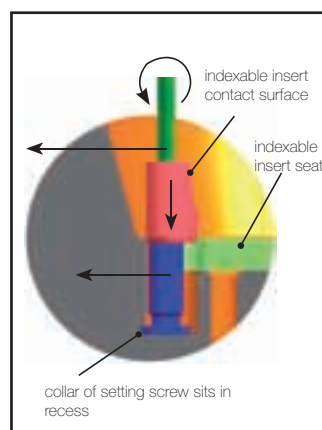

Fig. 2: ASSEMBLY

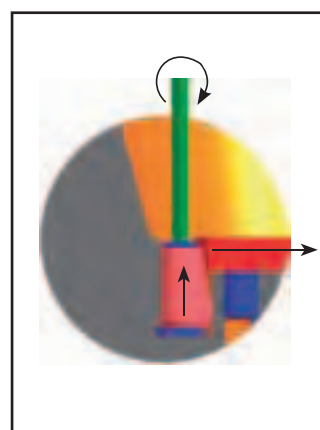

Fig. 3: OPERATION

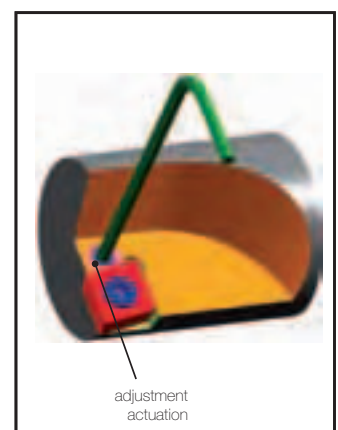

Fig. 4: OPERATION

# Setting and handling notes

## TWA fine adjustment for cartridges installation

### A. ASSEMBLY

1. Lightly lubricate the bottom and the wall of the location bore of the TWA as well as the thread of the setting screw with MOS2 assembly paste.
2. Enter the hexagonal key through the wedge into the hexagonal socket of the setting screw and insert together into the location bore of the adjustment unit to the bottom of the bore (fig. 5).
3. Using hexagonal key push setting screw into the radial recess at the bottom of the bore and screw-in the wedge anti-clockwise into the location bore to the block. In doing so the cartridge contact surface must be positioned opposite to the radial recess. Push the wedge from above onto the setting screw, so that the thread of the wedge can thread onto the setting screw (figure 6). If when screwing in the wedge the setting screw collar "jams" in the location bore (noticeable through the threaded pin being difficult to turn), press the entire adjustment unit into the location bore with the hexagonal key, if necessary resolve "jam" via clockwise rotation.
4. Lightly lubricate cartridge contact surface on the threaded key and the cartridge clamping screw thread with MOS2 assembly paste and screw in the cartridge clockwise into the cartridge seat with the cartridge clamping screw.
5. Screw in the indexable insert into the indexable insert seat of the cartridge (see tightening torque indexable insert clamping screws).
6. The disassembly is carried out in the reverse order.

### B. OPERATION:

1. Using key lightly tighten the cartridge clamping screw in a clockwise direction to the smallest dia. setting.
2. Adjust taper or diameter respectively via the TWA adjustment (fig. 7), whilst doing so move to within 0.05 mm in diameter of the setting dimension of the indexable insert (if necessary loosen cartridge clamping screw again).
3. Using key tighten cartridge clamping screw in clockwise direction (see tightening torque for cartridge clamping screws).
4. Adjust indexable insert setting dimension via TWA adjustment, if the dimension is exceeded simply loosen the TWA again and re-adjust.
5. If required lubricate the contact surfaces and the thread of the TWA adjustment unit with MOS2 assembly paste.

### C. MAX. TIGHTENING TORQUE CARTRIDGE SCREWS:

Thread size	Torx size	Tightening torque
M 6	Torx 25	1300 Ncm
M 5	Torx 20	900 Ncm
M 3.5	Torx 15	345 Ncm

### D. MAX. TIGHTENING TORQUE INDEX. INS. CLAMP. SCREWS:

Thread size	Torx size	Tightening torque
M 4 / M 4x0.5	Torx 15	515 Ncm
M 3.5	Torx 15	345 Ncm
M 2.5	Torx 8	128 Ncm
M 2.2 / M 2.5	Torx 7	101 Ncm

### E. KEY SIZES OF THE TWA ADJUSTMENT UNITS/ TRAVEL OF CARTRIDGE:

Cartridge size	Hexagonal socket	cartridge adjustment travel in radius
06	SW 1.5	0.024 mm at 1/4 rotation of setting screw
09	SW 2.0	
12	SW 3.0	

Axial adjustment travel: ±0.3mm (all sizes)

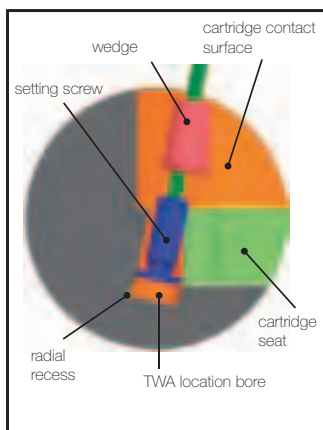

Fig. 5: ASSEMBLY

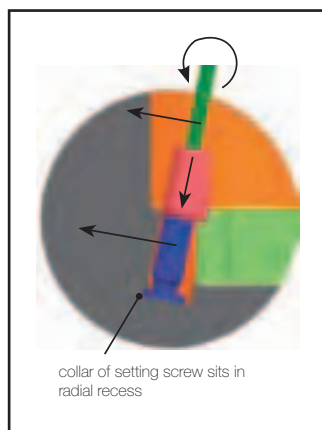

Fig. 6: ASSEMBLY

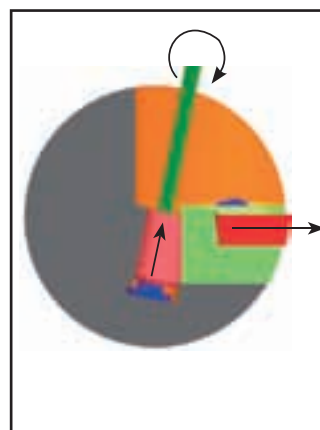

Fig. 7: OPERATION

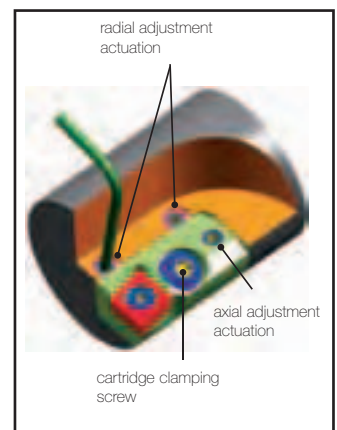
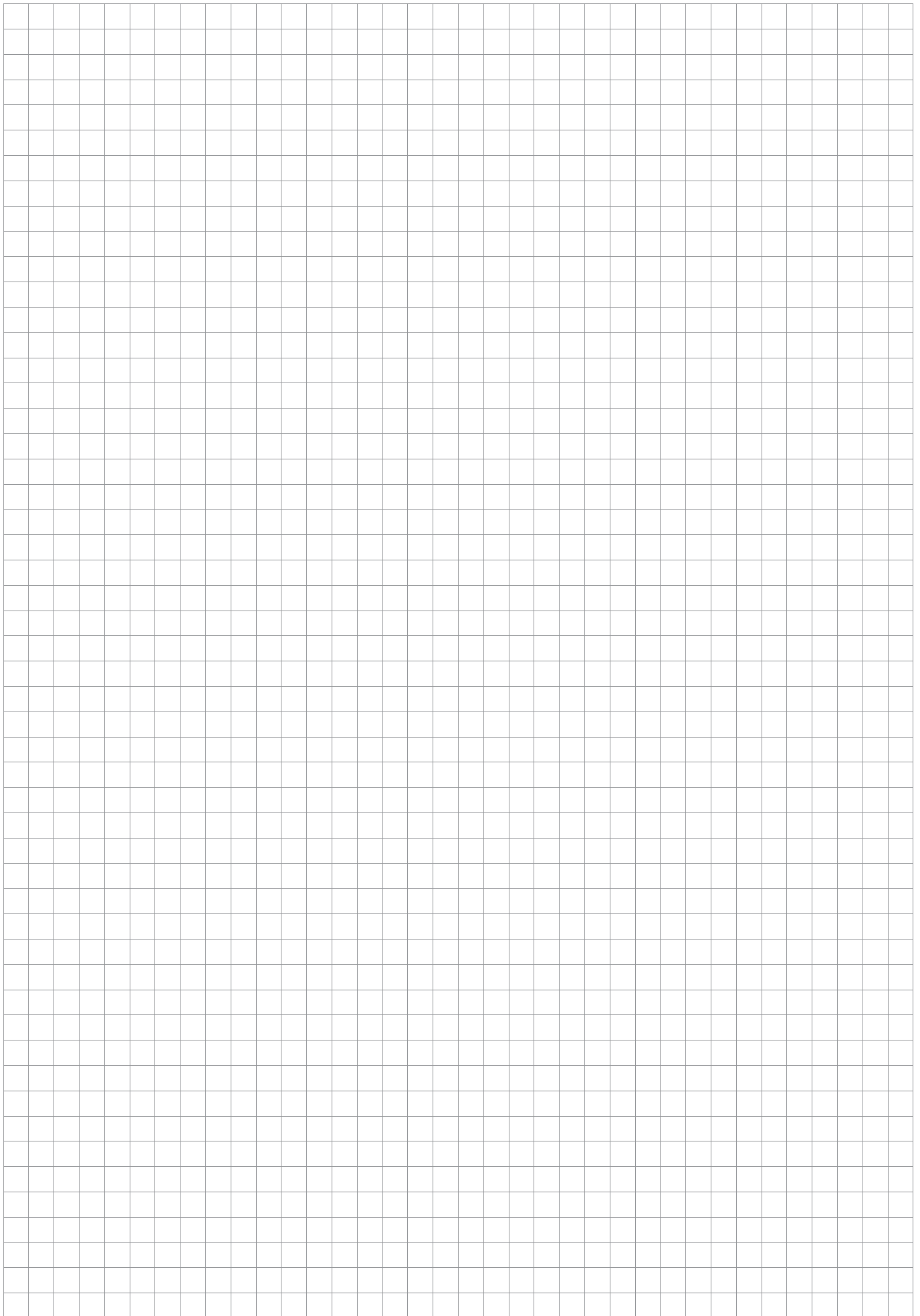

Fig. 8: OPERATION









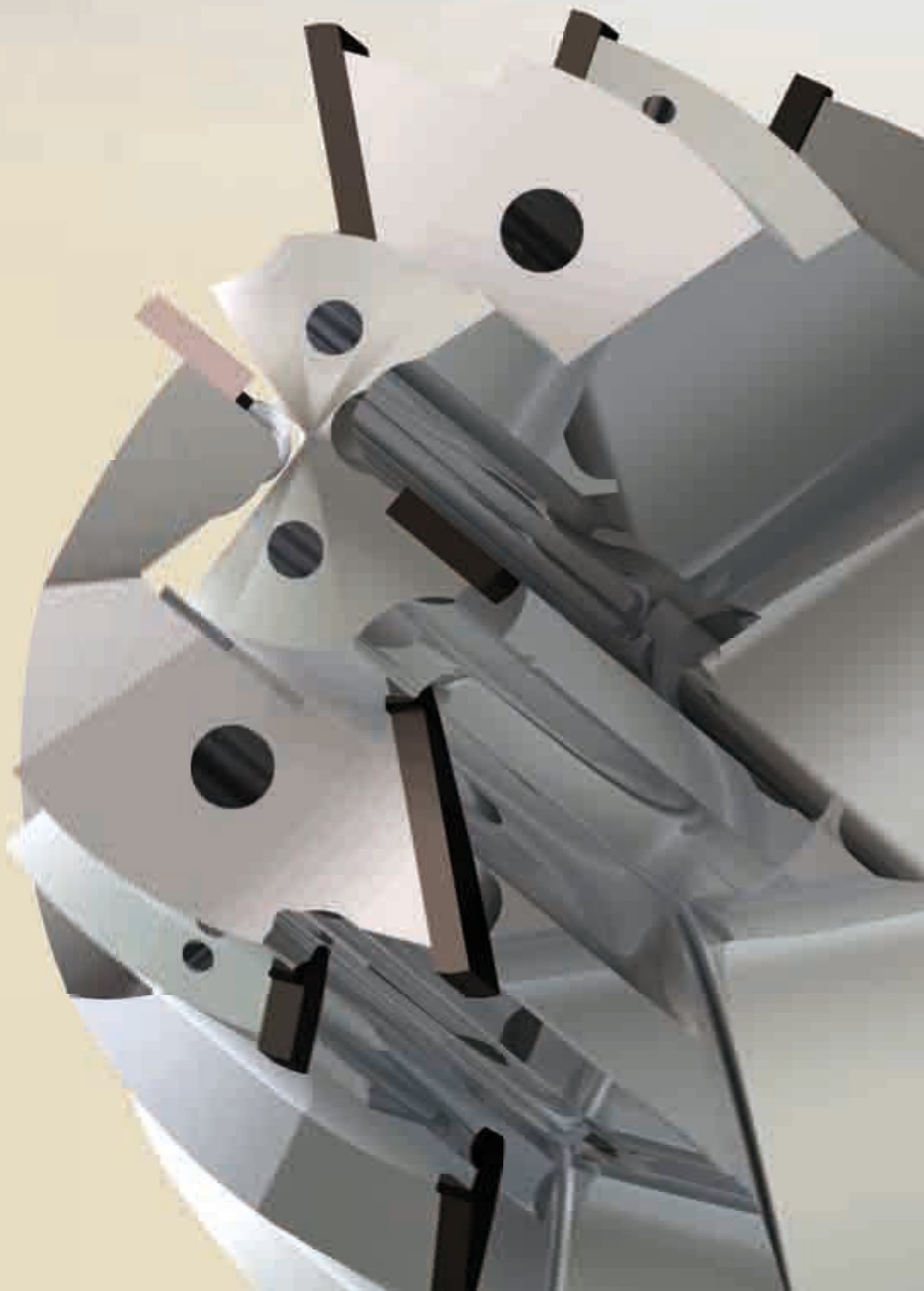



# GUHRING

PCD/CBN TECHNOLOGY



GUHRING KG | Telephone: +49 74 31 17 - 0 | Fax: +49 74 31 17 - 21 279

Herderstraße 50 - 54 | 72458 Albstadt | Germany | [info@guehring.de](mailto:info@guehring.de) | [www.guehring.de](http://www.guehring.de)