

GUHRING
The Tool Company



Deep Hole Drills

- **Spiral flute drilling from 15xD to 40xD**
- **CNC style solid carbide gun drills**
- **Miniature CNC style gun drills**
- **Classic gun drills with brazed head**

RT 100 T High penetration rate



EB 100 CNC style gun drill



EB 80 Standard gun drill

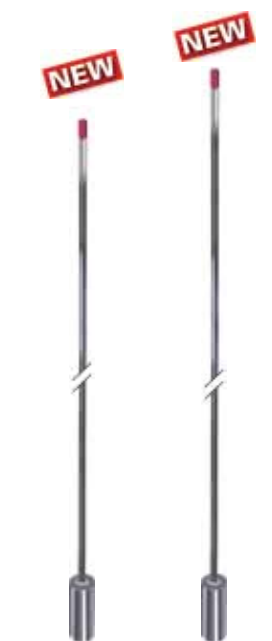

SERIES	6509	6511	6512	6513	6514
Style	RT 100 T	RT 100 T	RT 100 T	RT 100 T	RT 100 T
Point Angle	135°	135°	135°	135°	135°
Length	15 x D	20 x D	25 x D	30 x D	40 x D
Shank					
Coolant					
Carbide Grade	DK460UF	DK460UF	DK460UF	DK460UF	DK460UF
Surface Finish	TiAIN	TiAIN	TiAIN	TiAIN	TiAIN
Std. Dia. Range mm	3.0 - 14.0	3.0 - 14.0	3.0 - 12.0	3.0 - 10.0	3.0 - 8.0
Std. Dia. Range In.	0.1181-0.5512	0.1181-0.5512	0.1181-0.4724	0.1181-0.3937	0.1181-0.3150

SERIES	5646	5647	5648
Style	EB 100	EB 100	EB 100
Special	Special	Special	Special
Length	25 x D	50 x D	75 x D
Shank			
Coolant			
Carbide Grade	K30/K40	K30/K40	K30/K40
Surface Finish	nano-A™	nano-A™	nano-A™
Std. Dia. Range mm	1.2 - 3.2	1.2 - 5.0	1.5 - 5.0
Std. Dia. Range In.	0.0472-0.1260	0.0472-0.1969	0.0591-0.1969

SERIES	5641	5642
Style	EB 80	EB 80
Special	Special	Special
Length	45 x D	80 x D
Shank		
Coolant		
Carbide Grade	K30/K40	K30/K40
Surface Finish	TiCN	TiCN
Std. Dia. Range mm	3.9 - 12.7	4.95 - 12.65
Std. Dia. Range In.	0.1563-0.5000	0.1949-0.4980

RT 100 T - High penetration rates

- 3 to 5 times the penetration rate of gun drills or cobalt deep hole drills
- Eliminates peck cycles
- Reduces cycle times and increases production

Optimized flute geometry

These spiral-flute deep hole carbide drills possess an advanced flute geometry designed for optimal chip evacuation from deep holes in a wide range of materials.

Maximized coolant duct profile

To provide the cutting edge with an optimum coolant supply, the tools possess a maximized coolant duct profile. It ensures an efficient coolant supply to the cutting edge as well as excellent chip evacuation.

Problem-free chips

The design features of this drill – with the appropriate cutting parameters – result in chips that are evacuated problem-free even from deep holes. Chip packing and a subsequent jamming of the tool is effectively prevented.

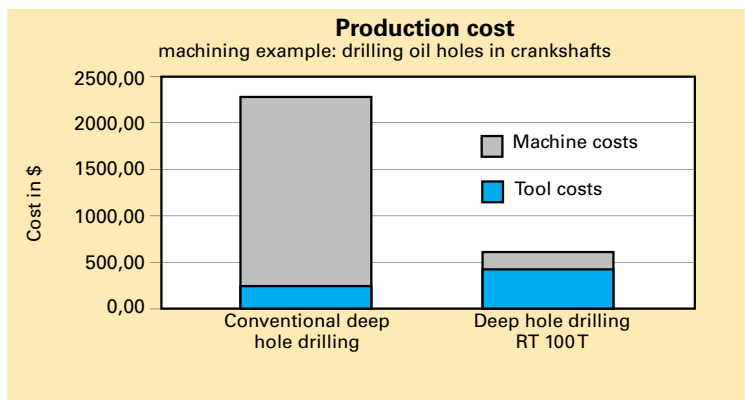

Ultimate cost-efficiency: Applied on machining centers, where the drilling operation is a time-relevant criterion, RT 100 T can display its superiority. Its high feed rates lead to a shorter production time, its long tool life reduces the number of tool changes.

Deep Hole Drills

EB 100 - Gun drill depths on CNC equipment

- **Solid carbide flute construction**
- **Precision hole making**
- **Extra deep hole drilling on CNC equipment**

The best of both worlds

CNC gun drills are a single flute tool designed to drill extra deep holes on conventional CNC machining centers without the need for specialized gun drill equipment. Drilling depths of over 75xD can be reached with the new EB 100 CNC style gun drill.

An excellent job shop selection

These precision deep hole drills have full carbide construction from the shank to the cutting edge with no brazed head flute construction using Guhring's ultra fine grain carbide. The nano-A™ coated point improves abrasion resistance at the cutting edge and increases the temperature at which these drills can effectively operate. The specialized point grind is a universal design that is well suited to the job shop environment.

Performance matters

Solid carbide construction provides improved rigidity within the cut and maximum hole size and location accuracies. Carbide CNC gun drills do not require peck cycles in most applications. They are best suited for hole depths that are beyond the reach of the RT 100T style spiral fluted drill. Pilot hole drilling is required before any application of the EB 100 style CNC gun drill.

EB 80 - Standard Gun Drills

- **Brazed head construction**
- **Single flute design**
- **TiCN coated head**

Maximum drilling depths

Designed for maximum drilling depths, Guhring conventional gun drills are coated carbide headed drills that allow manufacturers to achieve precision holes in a wide variety of materials. Brazed carbide headed gun drills are typically used for precise drilling of deep holes when conventional style drills cannot be employed.

Wide range of stocked standards; special designs available

Conventional gun drills provide excellent surface quality and finish hole concentricity when properly applied. All gun drills must have a pilot hole (conventional machines) or support bushings (deep hole drilling machines) to operate effectively. Guhring offers a wide range of styles and sizes with the series 5641 (45xD) and 5642 (80xD) versions highlighted in this brochure. Contact Guhring for a more complete listing of standard stocked conventional style gun drills or have Guhring quote a special design to meet your specific requirements.

EB 100 Fixed length miniature CNC style gun drill



	5024	5020	5026	5021
	EB 100	EB 100	EB 100	EB 100
	Special	Special	Special	Special
	45mm FL	80mm FL	120mm FL	160mm FL
	K30/K40	K30/K40	K30/K40	K30/K40
	Bright	Bright	Bright	Bright
Dia. range	1.2- 3.2 mm	1.2- 5.0 mm	1.5- 5.0 mm	1.5- 8.0 mm
	0.0472- 0.1260"	0.0472- 0.1969"	0.0591- 0.1969"	0.0591- 0.3150"

EB 100 - Fixed Length / Miniature CNC Gun Drills

- **Solid carbide flute construction**
- **Small diameter deep hole drilling capabilities on CNC equipment**
- **Oversized shank design**

Small diameter, extra length drilling

EB 100 fixed length miniature CNC gun drills are one piece carbide construction with oversized common shanks. These rigid single flute gun drills are best suited for small diameter extra length drilling operations where conventional drills can't be effectively used.

Coolant through the drill

Coolant fed EB 100 miniature CNC gun drills start at 1.2 mm diameter (0.0472") and can be used on any CNC machining center that is equipped with coolant through the spindle capabilities. These drills require a pilot hole. Guhring recommends using Series 6400 carbide micro-precision drills for precision piloting operations.

RT 100 T

High penetration rates

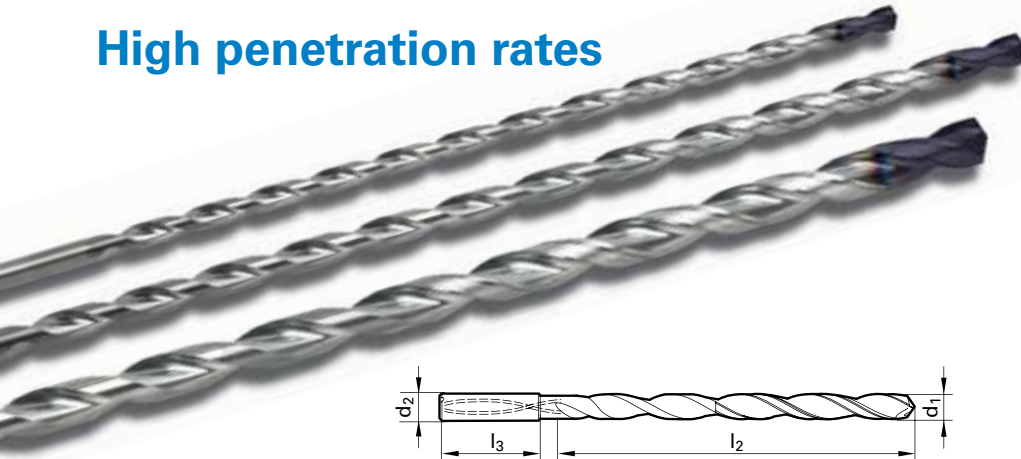

- High penetration rates
- Unique double margin design
- Specialized flute form
- High polished flute
- TiAlN coated tip
- 135° point angle

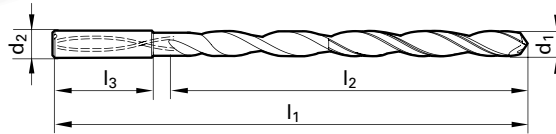

NEW

Series 6509 (15xD)

Series 6511 (20xD)

Diameter (d1)				d2 mm	l1 mm	l2 mm	l3 mm
Dec. inch	Fract. inch	Wire / letter	mm				
0.1181			3.000	6.00	95.00	55.00	36.00
0.1250	1/8		3.170	6.00	106.00	67.00	36.00
0.1378			3.500	6.00	116.00	76.00	36.00
0.1406	9/64	28	3.570	6.00	116.00	76.00	36.00
0.1563	5/32		3.970	6.00	116.00	76.00	36.00
0.1575			4.000	6.00	116.00	76.00	36.00
0.1719	11/64		4.370	6.00	133.00	93.00	36.00
0.1772			4.500	6.00	133.00	93.00	36.00
0.1874	3/16		4.760	6.00	133.00	93.00	36.00
0.1969			5.000	6.00	133.00	93.00	36.00
0.2008			5.100	6.00	150.00	110.00	36.00
0.2030	13/64		5.160	6.00	150.00	110.00	36.00
0.2130		3	5.410	6.00	150.00	110.00	36.00
0.2165			5.500	6.00	150.00	110.00	36.00
0.2189	7/32		5.560	6.00	150.00	110.00	36.00
0.2344	15/64		5.950	6.00	150.00	110.00	36.00
0.2362			6.000	6.00	150.00	110.00	36.00
0.2500	1/4	E	6.350	8.00	167.00	127.00	36.00
0.2559			6.500	8.00	167.00	127.00	36.00
0.2656	17/64	H	6.750	8.00	167.00	127.00	36.00
0.2756			7.000	8.00	167.00	127.00	36.00
0.2811	9/32	K	7.140	8.00	183.00	143.00	36.00
0.2953			7.500	8.00	183.00	143.00	36.00
0.2969	19/64		7.540	8.00	183.00	143.00	36.00
0.3120	5/16		7.940	8.00	183.00	143.00	36.00
0.3150			8.000	8.00	183.00	143.00	36.00
0.3281	21/64		8.330	10.00	204.00	160.00	40.00
0.3346			8.500	10.00	204.00	160.00	40.00
0.3438	11/32		8.730	10.00	204.00	160.00	40.00
0.3543			9.000	10.00	204.00	160.00	40.00
0.3594	23/64		9.130	10.00	221.00	177.00	40.00
0.3750	3/8		9.520	10.00	221.00	177.00	40.00
0.3906	25/64		9.920	10.00	221.00	177.00	40.00
0.3937			10.000	10.00	221.00	177.00	40.00
0.4063	13/32		10.320	12.00	247.00	198.00	45.00
0.4219	27/64		10.720	12.00	247.00	198.00	45.00
0.4330			11.000	12.00	247.00	198.00	45.00
0.4370	7/16		11.110	12.00	263.00	214.00	45.00
0.4531	29/64		11.510	12.00	263.00	214.00	45.00
0.4688	15/32		11.910	12.00	263.00	214.00	45.00
0.4724			12.000	12.00	263.00	214.00	45.00
0.4843	31/64		12.300	14.00	297.00	248.00	45.00
0.5000	1/2		12.700	14.00	297.00	248.00	45.00
0.5157	33/64		13.100	14.00	297.00	248.00	45.00
0.5311	17/32		13.490	14.00	297.00	248.00	45.00
0.5469	35/64		13.890	14.00	297.00	248.00	45.00
0.5512			14.000	14.00	297.00	248.00	45.00

Diameter (d1)				d2 mm	l1 mm	l2 mm	l3 mm
Dec. inch	Fract. inch	Wire / letter	mm				
0.1181			3.000	6.000	110.00	70.00	36.00
0.1250	1/8		3.170	6.000	123.00	83.00	36.00
0.1378			3.500	6.000	136.00	96.00	36.00
0.1406	9/64	28	3.570	6.000	136.00	96.00	36.00
0.1563	5/32		3.970	6.000	136.00	96.00	36.00
0.1575			4.000	6.000	136.00	96.00	36.00
0.1719	11/64		4.370	6.000	158.00	118.00	36.00
0.1772			4.500	6.000	158.00	118.00	36.00
0.1874	3/16		4.760	6.000	158.00	118.00	36.00
0.1969			5.000	6.000	158.00	118.00	36.00
0.2008			5.100	6.000	158.00	118.00	36.00
0.2030	13/64		5.160	6.000	158.00	118.00	36.00
0.2130		3	5.410	6.000	180.00	140.00	36.00
0.2165			5.500	6.000	180.00	140.00	36.00
0.2189	7/32		5.560	6.000	180.00	140.00	36.00
0.2344	15/64		5.950	6.000	180.00	140.00	36.00
0.2362			6.000	6.000	180.00	140.00	36.00
0.2500	1/4	E	6.350	8.000	202.00	162.00	36.00
0.2559			6.500	8.000	202.00	162.00	36.00
0.2656	17/64	H	6.750	8.000	202.00	162.00	36.00
0.2756			7.000	8.000	202.00	162.00	36.00
0.2811	9/32	K	7.140	8.000	223.00	183.00	36.00
0.2953			7.500	8.000	223.00	183.00	36.00
0.2969	19/64		7.540	8.000	223.00	183.00	36.00
0.3120	5/16		7.940	8.000	223.00	183.00	36.00
0.3150			8.000	8.000	223.00	183.00	36.00
0.3281	21/64		8.330	10.000	249.00	205.00	40.00
0.3346			8.500	10.000	249.00	205.00	40.00
0.3438	11/32		8.730	10.000	249.00	205.00	40.00
0.3543			9.000	10.000	249.00	205.00	40.00
0.3594	23/64		9.130	10.000	271.00	227.00	40.00
0.3750	3/8		9.520	10.000	271.00	227.00	40.00
0.3906	25/64		9.920	10.000	271.00	227.00	40.00
0.3937			10.000	10.000	271.00	227.00	40.00
0.4063	13/32		10.320	12.000	302.00	242.00	40.00
0.4219	27/64		10.720	12.000	302.00	242.00	40.00
0.4330			11.000	12.000	302.00	253.00	40.00
0.4370	7/16		11.110	12.000	323.00	274.00	45.00
0.4531	29/64		11.510	12.000	323.00	274.00	45.00
0.4688	15/32		11.910	12.000	323.00	274.00	45.00
0.4724			12.000	12.000	323.00	274.00	45.00
0.4843	31/64		12.300	14.000	367.00	318.00	45.00
0.5000	1/2		12.700	14.000	367.00	318.00	45.00
0.5157	33/64		13.100	14.000	367.00	318.00	45.00
0.5311	17/32		13.490	14.000	367.00	318.00	45.00
0.5469	35/64		13.890	14.000	367.00	318.00	45.00
0.5512			14.000	14.000	367.00	318.00	45.00

Series 6512 (25xD)

Diameter (d1)				d2	l1	l2	l3
Dec. inch	Fract. inch	Wire / letter	mm				
0.1181			3.000	6.000	125.00	85.00	36.00
0.1250	1/8		3.170	6.000	141.00	101.00	36.00
0.1378			3.500	6.000	156.00	116.00	36.00
0.1406	9/64	28	3.570	6.000	156.00	116.00	36.00
0.1563	5/32		3.970	6.000	156.00	116.00	36.00
0.1575			4.000	6.000	156.00	116.00	36.00
0.1719	11/64		4.370	6.000	183.00	143.00	36.00
0.1772			4.500	6.000	183.00	143.00	36.00
0.1874	3/16		4.760	6.000	183.00	143.00	36.00
0.1969			5.000	6.000	183.00	143.00	36.00
0.2008			5.100	6.000	183.00	143.00	36.00
0.2030	13/64		5.160	6.000	183.00	143.00	36.00
0.2130		3	5.410	6.000	210.00	170.00	36.00
0.2165			5.500	6.000	210.00	170.00	36.00
0.2189	7/32		5.560	6.000	210.00	170.00	36.00
0.2344	15/64		5.950	6.000	210.00	170.00	36.00
0.2362			6.000	6.000	210.00	170.00	36.00
0.2500	1/4	E	6.350	8.000	237.00	197.00	36.00
0.2559			6.500	8.000	237.00	197.00	36.00
0.2656	17/64	H	6.750	8.000	237.00	197.00	36.00
0.2756			7.000	8.000	237.00	197.00	36.00
0.2811	9/32	K	7.140	8.000	263.00	223.00	36.00
0.2953			7.500	8.000	263.00	223.00	36.00
0.2969	19/64		7.540	8.000	263.00	223.00	36.00
0.3120	5/16		7.940	8.000	263.00	223.00	36.00
0.3150			8.000	8.000	263.00	223.00	36.00
0.3281	21/64		8.330	10.000	294.00	250.00	40.00
0.3346			8.500	10.000	294.00	250.00	40.00
0.3438	11/32		8.730	10.000	294.00	250.00	40.00
0.3543			9.000	10.000	294.00	250.00	40.00
0.3594	23/64		9.130	10.000	294.00	250.00	40.00
0.3750	3/8		9.520	10.000	321.00	277.00	40.00
0.3906	25/64		9.920	10.000	321.00	277.00	40.00
0.3937			10.000	10.000	321.00	277.00	40.00
0.4063	13/32		10.320	12.000	359.00	310.00	40.00
0.4219	27/64		10.720	12.000	359.00	310.00	40.00
0.4724			12.000	12.000	386.00	337.00	45.00
0.4330			11.000	12.000	396.00	337.00	45.00
0.4370	7/16		11.110	12.000	386.00	337.00	45.00
0.4531	29/64		11.510	12.000	386.00	337.00	45.00
0.4689	15/32		11.910	12.000	386.00	337.00	45.00
0.4724			12.000	12.000	386.00	337.00	45.00

Series 6513 (30xD)

Diameter (d1)				d2	l1	l2	l3
Dec. inch	Fract. inch	Wire / letter	mm				
0.1181			3.000	6.000	140.00	100.00	36.00
0.1250	1/8		3.170	6.000	158.00	118.00	36.00
0.1378			3.500	6.000	176.00	136.00	36.00
0.1406	9/64	28	3.570	6.000	176.00	136.00	36.00
0.1563	5/32		3.970	6.000	176.00	136.00	36.00
0.1575			4.000	6.000	176.00	136.00	36.00
0.1719	11/64		4.370	6.000	208.00	168.00	36.00
0.1772			4.500	6.000	208.00	168.00	36.00
0.1874	3/16		4.760	6.000	208.00	168.00	36.00
0.1969			5.000	6.000	208.00	168.00	36.00
0.2008			5.100	6.000	208.00	168.00	36.00
0.2030	13/64		5.160	6.000	208.00	168.00	36.00
0.2130		3	5.410	6.000	240.00	200.00	36.00
0.2165			5.500	6.000	240.00	200.00	36.00
0.2189	7/32		5.560	6.000	240.00	200.00	36.00
0.2344	15/64		5.950	6.000	240.00	200.00	36.00
0.2362			6.000	6.000	240.00	200.00	36.00
0.2500	1/4	E	6.350	8.000	272.00	232.00	36.00
0.2559			6.500	8.000	272.00	232.00	36.00
0.2656	17/64	H	6.750	8.000	272.00	232.00	36.00
0.2756			7.000	8.000	272.00	232.00	36.00
0.2811	9/32	K	7.140	8.000	303.00	263.00	36.00
0.2953			7.500	8.000	303.00	263.00	36.00
0.2969	19/64		7.540	8.000	303.00	263.00	36.00
0.3120	5/16		7.940	8.000	303.00	263.00	36.00
0.3150			8.000	8.000	303.00	263.00	36.00
0.3281	21/64		8.330	10.000	339.00	295.00	40.00
0.3346			8.500	10.000	339.00	295.00	40.00
0.3438	11/32		8.730	10.000	339.00	295.00	40.00
0.3543			9.000	10.000	339.00	295.00	40.00
0.3594	23/64		9.130	10.000	339.00	295.00	40.00
0.3750	3/8		9.520	10.000	371.00	327.00	40.00
0.3906	25/64		9.920	10.000	371.00	327.00	40.00
0.3937			10.000	10.000	371.00	327.00	40.00

Series 6514 (40xD)

Diameter (d1)				d2	l1	l2	l3
Dec. inch	Fract. inch	Wire / letter	mm				
0.1181			3.000	6.000	170.00	130.00	36.00
0.1248	1/8		3.170	6.000	193.00	153.00	36.00
0.1378			3.500	6.000	193.00	153.00	36.00
0.1406	9/64	28	3.570	6.000	216.00	176.00	36.00
0.1563	5/32		3.970	6.000	216.00	176.00	36.00
0.1575			4.000	6.000	216.00	176.00	36.00
0.1720	11/64		4.370	6.000	238.00	198.00	36.00
0.1772			4.500	6.000	238.00	198.00	36.00
0.1874	3/16		4.760	6.000	258.00	218.00	36.00
0.1969			5.000	6.000	258.00	218.00	36.00
0.2008			5.100	6.000	280.00	240.00	36.00
0.2031	13/64		5.160	6.000	280.00	240.00	36.00
0.2129		3	5.410	6.000	280.00	240.00	36.00
0.2165			5.500	6.000	280.00	240.00	36.00
0.2189	7/32		5.560	6.000	300.00	260.00	36.00
0.2343	15/64		5.950	6.000	300.00	260.00	36.00
0.2362			6.000	6.000	300.00	260.00	36.00
0.2500	1/4	E	6.350	8.000	322.00	282.00	36.00
0.2559			6.500	8.000	322.00	282.00	36.00
0.2657	17/64	H	6.750	8.000	342.00	302.00	36.00
0.2756			7.000	8.000	342.00	302.00	36.00
0.2811	9/32	K	7.140	8.000	363.00	323.00	36.00
0.2953			7.500	8.000	363.00	323.00	36.00
0.2969	19/64		7.540	8.000	383.00	343.00	36.00
0.3120	5/16		7.940	8.000	383.00	343.00	36.00
0.3150			8.000	8.000	383.00	343.00	36.00

- Minimum of 250 PSI coolant pressure recommended -



All deep hole drills must utilize a pilot hole.
Deep hole drills must never operate at full speed without support in the pilot hole.

Procedure:

- Machine a pilot hole with an m7 toleranced series 5514 RT 100 drill to a minimum pilot depth of 1 to 1.5 x D.
- Enter the pilot hole at a speed of approx. 300 RPM, and with a feed rate of approx. 19 - 20 IPM
- Start high coolant pressure and increase RPM.
- Continuous drilling to complete hole depth without peck cycle.
- For through holes with oblique exit, reduce the feed rate to 40% approx. 1 mm prior to break-through.
- After reaching hole depth reduce machine spindle RPM and withdraw.

EB 100

Miniature single flute CNC style gun drill Fixed flute lengths

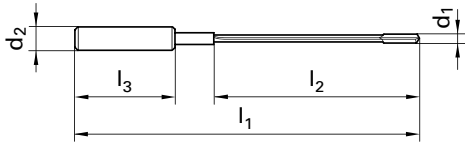

- Solid carbide flute gun drill - *no brazed head*
- Designed for CNC equipment - *no special gun drill machine needed*
- Coolant through the drill
- Excellent hole accuracy and surface finish

Diameter (d1)				Series 5024 45 mm flute			Series 5020 80 mm flute			Series 5026 120 mm flute			Series 5021 160 mm flute		
Dec. inch	Wire / letter	mm	d2 mm	l1 mm	l2 mm	l3 mm	l1 mm	l2 mm	l3 mm	l1 mm	l2 mm	l3 mm	l1 mm	l2 mm	l3 mm
0.0472		1.200	4.00	90.00	45.00	28.00	125.00	80.00	28.00	165.00	120.00	28.00	205.00	160.00	28.00
0.0591		1.500	4.000	90.00	45.00	28.00	125.00	80.00	28.00	165.00	120.00	28.00	205.00	160.00	28.00
0.0630		1.600	4.000	90.00	45.00	28.00	125.00	80.00	28.00	165.00	120.00	28.00	205.00	160.00	28.00
0.0787		2.000	4.000	90.00	45.00	28.00	125.00	80.00	28.00	165.00	120.00	28.00	205.00	160.00	28.00
0.0984		2.500	10.000	100.00	45.00	40.00	135.00	80.00	40.00	175.00	120.00	40.00	215.00	160.00	40.00
0.1063		2.700	10.000	100.00	45.00	40.00	135.00	80.00	40.00	175.00	120.00	40.00	215.00	160.00	40.00
0.1181		3.000	10.000	100.00	45.00	40.00	135.00	80.00	40.00	175.00	120.00	40.00	215.00	160.00	40.00
0.1260		3.200	10.000	100.00	45.00	40.00	135.00	80.00	40.00	175.00	120.00	40.00	215.00	160.00	40.00
0.1378		3.500	10.000				135.00	80.00	40.00	175.00	120.00	40.00	215.00	160.00	40.00
0.1575		4.000	10.000				135.00	80.00	40.00	175.00	120.00	40.00	215.00	160.00	40.00
0.1654		4.200	10.000				135.00	80.00	40.00	175.00	120.00	40.00	215.00	160.00	40.00
0.1772	16	4.500	10.000				135.00	80.00	40.00	175.00	120.00	40.00	215.00	160.00	40.00
0.1969		5.000	10.000				135.00	80.00	40.00	175.00	120.00	40.00	215.00	160.00	40.00
0.2362		6.000	16.000										225.00	160.00	48.00
0.3150		8.000	16.000										225.00	160.00	48.00

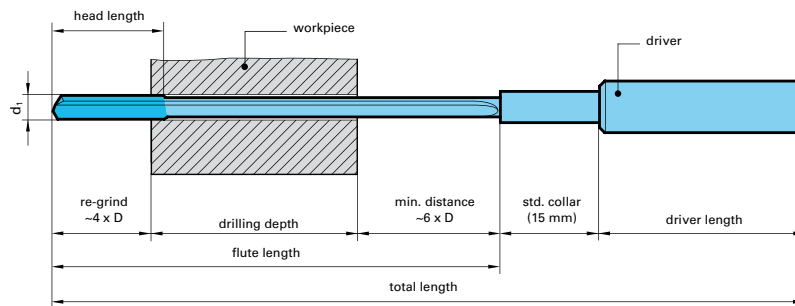

Procedure:

- Machine a pilot hole with an m7 toleranced series 5514 or series 6400 drill to a minimum pilot depth of 1 to 1.5 x D.
- Enter the pilot hole at a speed of approx. 300 RPM, and a feed rate of approx. 19 - 20 IPM
- Start high coolant pressure and increase RPM.
- Continuous drilling to complete hole depth without peck cycle.
- For through holes with oblique exit, reduce the feed rate to 40% approx. 1 mm prior to break-through.
- After reaching hole depth reduce machine spindle RPM and withdraw.



All deep hole drills must utilize a pilot hole.



EB 100

Single flute CNC style gun drill

25xD, 50xD or 75xD

NEW

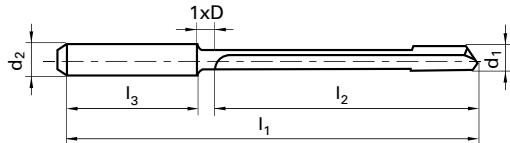

- Coolant fed carbide drill
- nano-A™ coated point
- Designed for CNC equipment -
no special gun drill machine needed
- Solid carbide flute gun drill -
no brazed head

Diameter (d1)			d2 mm	Series 5646 25 x D			Series 5647 50 x D			Series 5648 75 x D		
Dec. inch	Fract. inch	mm		l1 mm	l2 mm	l3 mm	l1 mm	l2 mm	l3 mm	l1 mm	l2 mm	l3 mm
0.0394		1.000	3.00	60.00	30.00	28.00	85.00	55.00	28.00	110.00	80.00	28.00
0.0591		1.500	4.00	80.00	50.00	28.00	120.00	85.00	28.00	155.00	125.00	28.00
0.0626	1/16	1.590	4.00	80.00	50.00	28.00	120.00	85.00	28.00	155.00	125.00	28.00
0.0780	5/64	1.980	4.00	100.00	70.00	28.00	160.00	130.00	28.00	220.00	190.00	28.00
0.0787		2.000	4.00	100.00	70.00	28.00	160.00	130.00	28.00	220.00	190.00	28.00
0.0937	3/32	2.380	4.00	100.00	70.00	28.00	160.00	130.00	28.00	220.00	190.00	28.00
0.0984		2.500	4.00	115.00	85.00	28.00	185.00	155.00	28.00	255.00	220.00	28.00
0.1094	7/64	2.780	4.00	115.00	85.00	28.00	185.00	155.00	28.00	255.00	220.00	28.00
0.1181		3.000	6.00	145.00	105.00	36.00	230.00	190.00	36.00	320.00	280.00	36.00
0.1248	1/8	3.170	6.00	145.00	105.00	36.00	230.00	190.00	36.00	320.00	280.00	36.00
0.1378		3.500	6.00	145.00	105.00	36.00	230.00	190.00	36.00	320.00	280.00	36.00
0.1563	5/32	3.970	6.00	160.00	120.00	36.00	260.00	220.00	36.00	360.00	320.00	36.00
0.1575		4.000	6.00	160.00	120.00	36.00	260.00	220.00	36.00	360.00	320.00	36.00
0.1969		5.000	6.00	220.00	180.00	36.00	370.00	330.00	36.00	525.00	485.00	36.00
0.2189	7/32	5.560	6.00	220.00	180.00	36.00	370.00	330.00	36.00	525.00	485.00	36.00
0.2362		6.000	6.00	220.00	180.00	36.00	370.00	330.00	36.00	525.00	485.00	36.00
0.2500	1/4	6.350	8.00	260.00	210.00	36.00	430.00	385.00	36.00			
0.2756		7.000	8.00	260.00	210.00	36.00	430.00	385.00	36.00			
0.2811	9/32	7.140	8.00	285.00	240.00	36.00	485.00	440.00	36.00			
0.3150		8.000	8.00	285.00	240.00	36.00	485.00	440.00	36.00			
0.3543		9.000	10.00	350.00	300.00	40.00						
0.3937		10.000	10.00	350.00	300.00	40.00						
0.4331		11.000	12.00	420.00	360.00	45.00						
0.4724		12.000	12.00	420.00	360.00	45.00						

EB 100

Standard point grinds

(special point grinds on request)

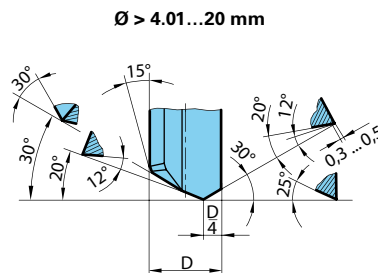
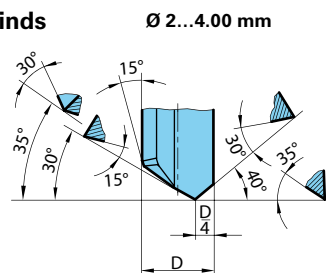

EB 100

Back taper ratio

(dimensions in mm)

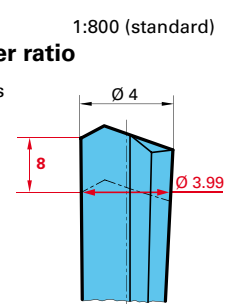

NEW

EB 80

Brazed single flute gun drill

Fixed flute lengths

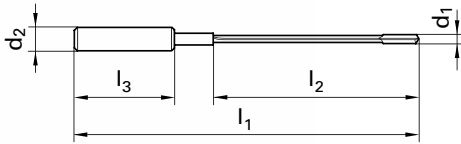
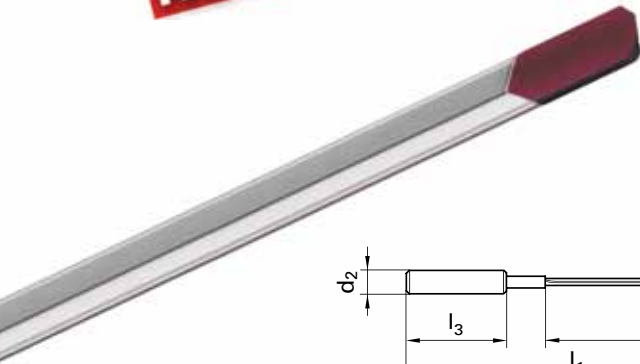

- **Brazed head construction**
- **Oversized universal shank**
- **TiCN coated tip**
- **Excellent hole accuracy and surface finish**

Diameter (d1)				Series 5641 40 x D		
Dec. inch	Fract. inch	mm	d2 mm	l1 mm	l2 mm	l3 mm
0.1563	5/32	3.970	10.00	230.00	185.00	40.00
0.1575		4.000	10.00	230.00	185.00	40.00
0.1969		5.000	16.00	280.00	232.00	48.00
0.2030	13/64	5.156	16.00	280.00	232.00	48.00
0.2362		6.000	16.00	320.00	272.00	48.00
0.2500		6.350	16.00	340.00	292.00	48.00
0.2756		7.000	16.00	370.00	322.00	48.00
0.3125	5/16	7.938	16.00	430.00	372.00	48.00
0.3150		8.000	16.00	430.00	372.00	48.00
0.3543		9.000	16.00	450.00	402.00	48.00
0.3750	3/8	9.525	16.00	480.00	432.00	48.00
0.3937		10.000	20.00	510.00	460.00	50.00
0.4331		11.000	20.00	550.00	500.00	50.00
0.4375	7/16	11.113	20.00	550.00	500.00	50.00
0.4724		12.000	20.00	600.00	550.00	50.00
0.5000	1/2	12.700	20.00	635.00	585.00	50.00

Diameter (d1)				Series 5642 80 x D		
Dec. inch	Fract. inch	mm	d2 mm	l1 mm	l2 mm	l3 mm
0.1949		4.950	16.00	480.00	432.00	48.00
0.2010		5.106	16.00	480.00	432.00	48.00
0.2343		5.950	16.00	560.00	512.00	48.00
0.2480		6.300	16.00	590.00	542.00	48.00
0.2539		6.450	16.00	590.00	542.00	48.00
0.2736		6.950	16.00	650.00	602.00	48.00
0.3106		7.888	16.00	740.00	692.00	48.00
0.3130		7.950	16.00	740.00	692.00	48.00
0.3524		8.950	16.00	820.00	772.00	48.00
0.3730		9.475	16.00	870.00	822.00	48.00
0.3917		9.950	20.00	910.00	860.00	50.00
0.4311		10.950	20.00	995.00	945.00	50.00
0.4356		11.063	20.00	995.00	945.00	50.00
0.4705		11.950	20.00	1080.00	1030.00	50.00
0.4980		12.650	20.00	1140.00	1090.00	50.00

Drill diameters for the 80xD EB 80 Series 5642 are offered as stocked standards in increments of -0.05mm (0.0019") below the nominal diameter of the pilot tool, which is normally an RT 100 T high penetration rate drill or EB 80 40xD series 5641 standard gun drill. Guhring recommends a full depth pilot drill of 40xD followed by series 5642 EB 80 finish drill.

EB 80 standard point grinds

(special point grinds available)

Ø 2.00-4.00 mm

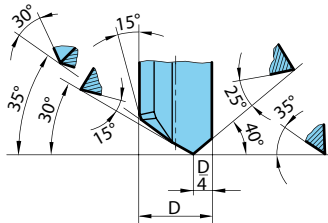

Ø 4.01-20.00 mm

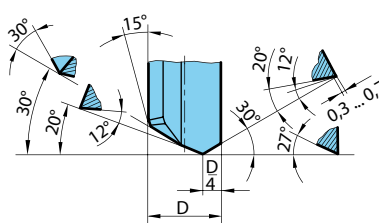

Ø 20.01-40.00 mm

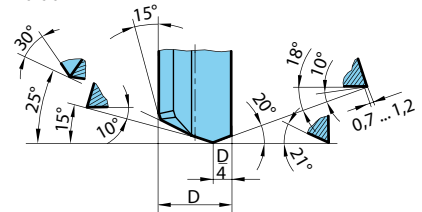

Tech Tip:

Gun drills hold location to precise tolerances in extremely deep hole applications. Conventional gun drills consist of a steel body and driver with a brazed carbide head for extended tool life and performance. When applying standard gun drills some basic steps should be observed:

- Drilling a pilot hole (tol. h8) is advisable. Enter the pilot hole at low RPM and feed rate (example: 200 RPM at 20 in/min)
- Gun drills for drilling depths over 40xD should enter pilot hole in a counterclockwise direction.
- Continuous drilling without pecking is required.
- Switch off coolant supply after reaching maximum drilling depth.
- Use a rapid withdrawal with a stationary spindle.

Technical Information

Deep hole drilling on conventional machine tools

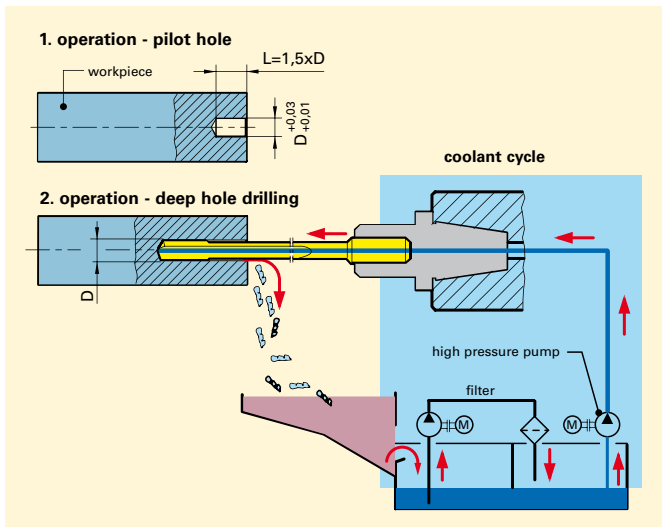

Deep hole drilling machines

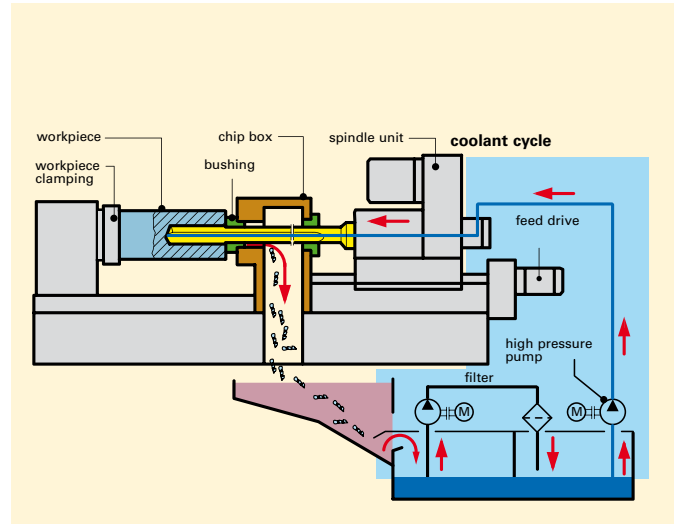

Operating Parameters

Using These Tables. The Speeds & Feeds listed below are conservative recommendations for initial setup. In actual use, depending on the machining environment and workpiece material, significantly higher speeds and feeds may be achievable. Using the below as a starting point, cutting speed/feed can be gradually adjusted upwards until the optimum settings per application are found. Questions? Contact us by telephone at (800) 776-6170.

Series # 6509 & 6511

Material group	Hardness	SFM	Feed Rate - IPR									
			1/16 in. 1.590 mm	1/8 in. 3.170 mm	1/4 in. 6.350 mm	3/8 in. 9.520 mm	1/2 in. 12.700 mm	5/8 in. 15.870 mm	3/4 in. 19.050 mm	1 in. 25.400 mm	1 1/4 in. 31.750 mm	1 1/2 in. 38.100 mm
Common structural steels	≤100 Bhn	360	0.004	0.006	0.010	0.014	0.016	0.020				
	>100-260 Bhn	360	0.004	0.006	0.010	0.014	0.016	0.020				
Free-cutting steels	≤24 Rc	395	0.004	0.006	0.010	0.014	0.016	0.020				
	>24-30 Rc	395	0.004	0.006	0.010	0.014	0.016	0.020				
Unalloyed heat-treatable steels	≤16 Rc	360	0.003	0.004	0.006	0.009	0.010	0.012				
	16-24 Rc	360	0.004	0.006	0.010	0.014	0.016	0.020				
	24-30 Rc	330	0.003	0.005	0.008	0.011	0.012	0.016				
Alloyed heat-treatable steels	24-30 Rc	360	0.003	0.005	0.008	0.011	0.012	0.016				
	>30-38 Rc	360	0.003	0.004	0.006	0.009	0.010	0.012				
Unalloyed case hardened steels	≤230 Bhn	360	0.004	0.006	0.010	0.014	0.016	0.020				
Alloyed case hardened steels	24-30 Rc	360	0.003	0.005	0.008	0.011	0.012	0.016				
	>30-38 Rc	360	0.003	0.004	0.006	0.009	0.010	0.012				
Nitriding steels	≥24-30 Rc	330	0.002	0.003	0.005	0.007	0.008	0.010				
	>30-38 Rc	260	0.002	0.003	0.005	0.007	0.008	0.010				
Tool steels	≤24 Rc	330	0.003	0.004	0.006	0.009	0.010	0.012				
	>24-30 Rc	260	0.002	0.003	0.005	0.007	0.008	0.010				
High speed steels	≥14-30 Rc	165	0.002	0.003	0.005	0.007	0.008	0.010				
Spring steels	≤330 Bhn	165	0.002	0.003	0.005	0.007	0.008	0.010				
Stainless steels, sulphured	≤24 Rc	330	0.002	0.003	0.005	0.007	0.008	0.010				
	austenitic	≤24 Rc	230	0.001	0.002	0.002	0.004	0.004	0.005			
	martensitic	≤24 Rc	330	0.002	0.003	0.005	0.007	0.008	0.010			
Hardened steels	≤40-48 Rc	165	0.002	0.002	0.004	0.006	0.006	0.008				
	>48-60 Rc	165	0.001	0.002	0.004	0.006	0.006	0.008				
Special alloys	≤38 Rc	100	0.004	0.002	0.002	0.004	0.004	0.005				
Cast iron	≤240 Bhn	460	0.004	0.006	0.010	0.014	0.016	0.020				
	<300 Bhn	330	0.004	0.006	0.010	0.014	0.016	0.020				
Spheroidal graphite iron and malleable cast iron	≤240 Bhn	460	0.004	0.006	0.010	0.014	0.016	0.020				
	<300 Bhn	330	0.004	0.006	0.010	0.014	0.016	0.020				
Chilled cast iron	≤350 Bhn	•	•	•	•	•	•	•				
Ti and Ti-alloys	≤24 Rc	•	•	•	•	•	•	•				
	>24-38 Rc	•	•	•	•	•	•	•				
Aluminium and Al-alloys	≤120 Bhn	•	•	•	•	•	•	•				
Al wrought alloys	≤150 Bhn	•	•	•	•	•	•	•				
Al cast alloys ≤ 10 % Si	≤200 Bhn	•	•	•	•	•	•	•				
	> 10 % Si	≤200 Bhn	•	•	•	•	•	•				
Magnesium alloys	≤150 Bhn	•	•	•	•	•	•	•				
Copper, low-alloyed	≤120 Bhn	395	•	0.001	0.002	0.003	0.003	0.004				
Brass, short-chipping	≤200 Bhn	395	0.004	0.006	0.010	0.014	0.016	0.020				
	long-chipping	≤200 Bhn										
Bronze, short-chipping	≤200 Bhn											
	>200-260 Bhn											
Bronze, long-chipping	≤24 Rc											
	>24-30 Rc											
Duroplastics	-											
Thermoplastics	-											
Reinforced plastics - Kevlar	-											
Reinforced plastics - GFK / CFK	-											

Note: Pilot holes (depth >1xD) are recommended when using RT100T drills. Use a series 5514 or similar drill to drill a minimum of 1xD deep. Then enter the pilot hole with the RT100T drill at approx 300 rev/min and 500 mm/min speed, start high coolant pressure and increase RPM. Drill to hole depth without pecking.

EB 80 Greater than 35xD

Material group	Hardness	SFM	Feed Rate - IPR									
			1/16 in. 1.590 mm	1/8 in. 3.170 mm	1/4 in. 6.350 mm	3/8 in. 9.520 mm	1/2 in. 12.700 mm	5/8 in. 15.870 mm	3/4 in. 19.050 mm	1 in. 25.400 mm	1 1/4 in. 31.750 mm	1 1/2 in. 38.100 mm
Common structural steels	≤100 Bhn	330	0.0002	0.0003	0.0005	0.0009	0.0011	0.0014	•	•	•	•
	>100-260 Bhn	280	0.0002	0.0003	0.0005	0.0009	0.0011	0.0014	•	•	•	•
Free-cutting steels	≤24 Rc	295	0.0002	0.0003	0.0005	0.0009	0.0011	0.0014	•	•	•	•
	>24-30 Rc	265	0.0002	0.0003	0.0005	0.0009	0.0011	0.0014	•	•	•	•
Unalloyed heat-treatable steels	≤16 Rc	295	0.0002	0.0002	0.0004	0.0006	0.0006	0.0010	•	•	•	•
	16-24 Rc	265	0.0002	0.0002	0.0004	0.0006	0.0006	0.0010	•	•	•	•
	24-30 Rc	245	0.0002	0.0002	0.0004	0.0006	0.0006	0.0010	•	•	•	•
Alloyed heat-treatable steels	24-30 Rc	245	0.0002	0.0002	0.0004	0.0006	0.0006	0.0010	•	•	•	•
	>30-38 Rc	215	0.0002	0.0002	0.0004	0.0006	0.0006	0.0010	•	•	•	•
Unalloyed case hardened steels	≤230 Bhn	265	0.0002	0.0003	0.0005	0.0009	0.0011	0.0014	•	•	•	•
Alloyed case hardened steels	24-30 Rc	245	0.0002	0.0002	0.0004	0.0006	0.0006	0.0010	•	•	•	•
	>30-38 Rc	215	0.0002	0.0002	0.0004	0.0006	0.0006	0.0010	•	•	•	•
Nitriding steels	≥24-30 Rc	245	0.0002	0.0002	0.0004	0.0006	0.0006	0.0010	•	•	•	•
	>30-38 Rc	215	0.0002	0.0002	0.0004	0.0006	0.0006	0.0010	•	•	•	•
Tool steels	≤24 Rc	245	0.0001	0.0002	0.0003	0.0004	0.0005	0.0008	•	•	•	•
	>24-30 Rc	215	0.0001	0.0002	0.0003	0.0004	0.0005	0.0008	•	•	•	•
High speed steels	≥14-30 Rc	180	0.0001	0.0002	0.0003	0.0004	0.0005	0.0008	•	•	•	•
Spring steels	≤330 Bhn	215	0.0001	0.0002	0.0003	0.0004	0.0005	0.0008	•	•	•	•
Stainless steels, sulphured austenitic martensitic	≤24 Rc	180	0.0002	0.0002	0.0004	0.0006	0.0006	0.0010	•	•	•	•
	≤24 Rc	150	0.0002	0.0002	0.0004	0.0006	0.0006	0.0010	•	•	•	•
	≤24 Rc	115	0.0002	0.0002	0.0004	0.0006	0.0006	0.0010	•	•	•	•
Hardened steels	≤40-48 Rc	100	0.0001	0.0002	0.0003	0.0004	0.0005	0.0008	•	•	•	•
	>48-60 Rc	85	0.0001	0.0002	0.0003	0.0004	0.0005	0.0008	•	•	•	•
Special alloys	≤38 Rc	115	0.0001	0.0002	0.0003	0.0004	0.0005	0.0008	•	•	•	•
Cast iron	≤240 Bhn	180	0.0003	0.0005	0.0009	0.0013	0.0016	0.0020	•	•	•	•
	<300 Bhn	160	0.0003	0.0005	0.0009	0.0013	0.0016	0.0020	•	•	•	•
Spheroidal graphite iron and malleable cast iron	≤240 Bhn	260	0.0002	0.0003	0.0005	0.0009	0.0011	0.0014	•	•	•	•
	<300 Bhn	230	0.0002	0.0003	0.0005	0.0009	0.0011	0.0014	•	•	•	•
Chilled cast iron	≤350 Bhn	180	0.0002	0.0002	0.0004	0.0006	0.0006	0.0010	•	•	•	•
Ti and Ti-alloys	≤24 Rc	115	0.0001	0.0002	0.0003	0.0004	0.0005	0.0008	•	•	•	•
	>24-38 Rc	100	0.0001	0.0002	0.0003	0.0004	0.0005	0.0008	•	•	•	•
Aluminium and Al-alloys	≤120 Bhn	590	0.0005	0.0007	0.0014	0.0018	0.0022	0.0026	•	•	•	•
Al wrought alloys	≤150 Bhn	655	0.0003	0.0005	0.0009	0.0013	0.0016	0.0020	•	•	•	•
Al cast alloys ≤ 10 % Si > 10 % Si	≤200 Bhn	525	0.0005	0.0007	0.0014	0.0018	0.0022	0.0026	•	•	•	•
	≤200 Bhn	395	0.0005	0.0007	0.0014	0.0018	0.0022	0.0026	•	•	•	•
Magnesium alloys	≤150 Bhn	245	0.0005	0.0007	0.0014	0.0018	0.0022	0.0026	•	•	•	•
Copper, low-alloyed	≤120 Bhn	395	0.0002	0.0003	0.0005	0.0009	0.0011	0.0014	•	•	•	•
Brass, short-chipping long-chipping	≤200 Bhn	295	0.0008	0.0012	0.0024	0.0027	0.0030	0.0033	•	•	•	•
	≤200 Bhn	215	0.0008	0.0012	0.0024	0.0027	0.0030	0.0033	•	•	•	•
Bronze, short-chipping	≤200 Bhn	245	0.0005	0.0007	0.0014	0.0018	0.0022	0.0026	•	•	•	•
	>200-260 Bhn	230	0.0005	0.0007	0.0014	0.0018	0.0022	0.0026	•	•	•	•
Bronze, long-chipping	≤24 Rc	230	0.0005	0.0007	0.0014	0.0018	0.0022	0.0026	•	•	•	•
	>24-30 Rc	230	0.0005	0.0007	0.0014	0.0018	0.0022	0.0026	•	•	•	•
Duroplastics	-	230	0.0002	0.0003	0.0005	0.0009	0.0011	0.0014	•	•	•	•
Thermoplastics	-	200	0.0002	0.0003	0.0005	0.0009	0.0011	0.0014	•	•	•	•
Reinforced plastics - Kevlar	-	165	0.0002	0.0002	0.0004	0.0006	0.0006	0.0010	•	•	•	•
Reinforced plastics - GFK / CFK	-	-	-	-	-	-	-	-	•	•	•	•

Coolant values RT 100 T

(Recommended values for soluble oil)

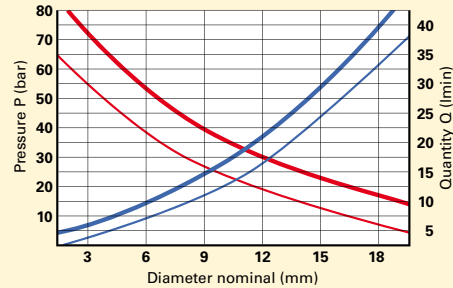

— Coolant pressure max. — Coolant quantity max.
— Coolant pressure min. — Coolant quantity min.

Coolant values EB 100

(Recommended values for soluble oil)

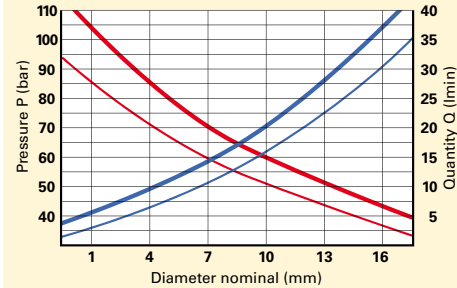

— Coolant pressure max. — Coolant quantity max.
— Coolant pressure min. — Coolant quantity min.

Coolant values EB 80

(Recommended values for soluble oil)

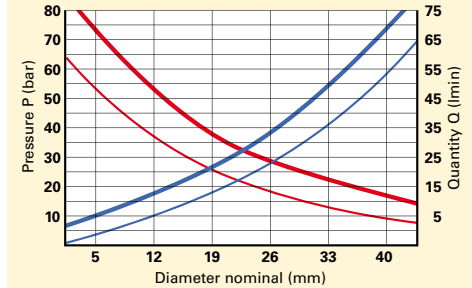

— Coolant pressure max. — Coolant quantity max.
— Coolant pressure min. — Coolant quantity min.

GUHRING

The Tool Company

Guhring, Inc.

P.O. Box 643, Brookfield, WI 53008-0643

Shipping Address

1445 Commerce Avenue
Brookfield, WI 53045

Tel (262) 784-6730 (800) 776-6170

Fax (262) 784-9096

www.guhring.com

West Coast Distribution Center

17902 Georgetown Lane
Huntington Beach, CA 92647

Guhring Corporation

20 Steckle Place, Unit #14
Kitchener, ON N2E 2C3

Tel (519) 748-9664 (800) 463-5555

Fax (519) 748-2954